

GENERAL SPECIFICATIONS:

MANUFACTURER'S QUALIFICATIONS

Petersen Mfg. maintains at all times a quality control program as herein outlines so as to insure that all precast meets all requirements as specified under physical requirements. All precast shall be manufactured by skilled workmen who have at least five years experience in similar work and supervised by foremen certified by the ACI (American Concrete Institute).

MANUFACTURING

All precast work shall be true to dimensions and have clean, accurate arises and details faithfully executed. Reinforcing steel shall conform to ASTM 615 for rebar, and deformations shall conform to ASTM-M-0305. All precast shall have a minimum compressive strength of 5,000 psi at 28 days of age when tested by means of 6 x 12 cylinder molds from the materials. There shall be a maximum of 4-6% air entrainment for all precast according to ASTM standards.

REINFORCEMENT

All concrete products have reinforcement characteristics such as rebar or fiberglass.

MOLDS

The forms for the precast units shall be constructed of metal or fiberglass, and designed to withstand casting pressures without distortion. All anchors, inserts, bolts, etc., will be placed and secured in the forms as required for the attachment and handling of the units. These shall be clamped or secured so as to hold them in position during fabrication.

PHYSICAL CHARACTERISTICS

All exposed surfaces are treated to remove the surface matrix and expose the aggregate produced by chemical retardent - not sand blasting. All precast shall have water-repellent sealer treatment applied in strict accordance with manufacturer's specifications. All tolerances shall be within 1/8" of specified dimensions, designed for structural analysis and calculation.

COLOR

Color to be uniform throughout as approved by owner or specifier in accordance with manufacturer's recommendation.

MATERIALS

Portland Cement: ASTM C150 Type I or III
All aggregate to meet ASTM C33 Specifications

REQUIRED MATERIALS FOR APPROVAL

- A. Shop drawings with dimensions, general construction component parts, anchoring details and installation instructions.
- B. Samples upon request of architect.
- C. Complete data on manufacturer's specifications and technical information.

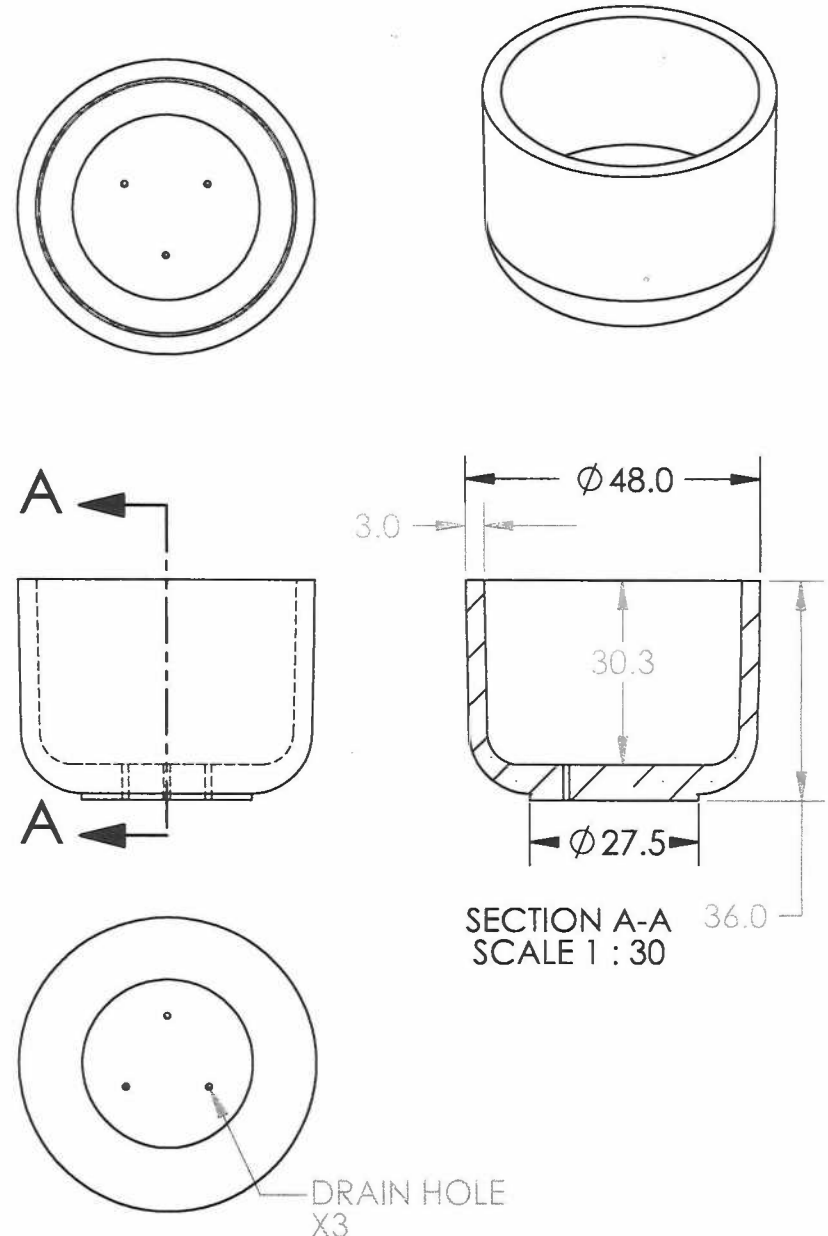

Model: RP48X36
Weight: 1800 LBS

CP R 4836