

NO.	PART NUMBER	DESCRIPTION	MATERIAL	QTY.
1	DPT-SA1	TABLE DUAL POST IN GROUND		2
2	8IPTV-9	8'VP TOP SUB ASSY		1
3	8IV-8	8' VP SEAT SUB ASSY		2
4	Regular FW 0.375	3/8" REGULAR FLAT WASHER		12
5	HBOLT 0.3750-16x1.5x1-N	HEX HEAD BOLT 3/8"-16x 1 1/2"		12
6	Regular LW 0.375	LOCK WASHER 3/8"		12
7	HNUT 0.3750-16-D-N	HEX NUT 3/8"-16		12

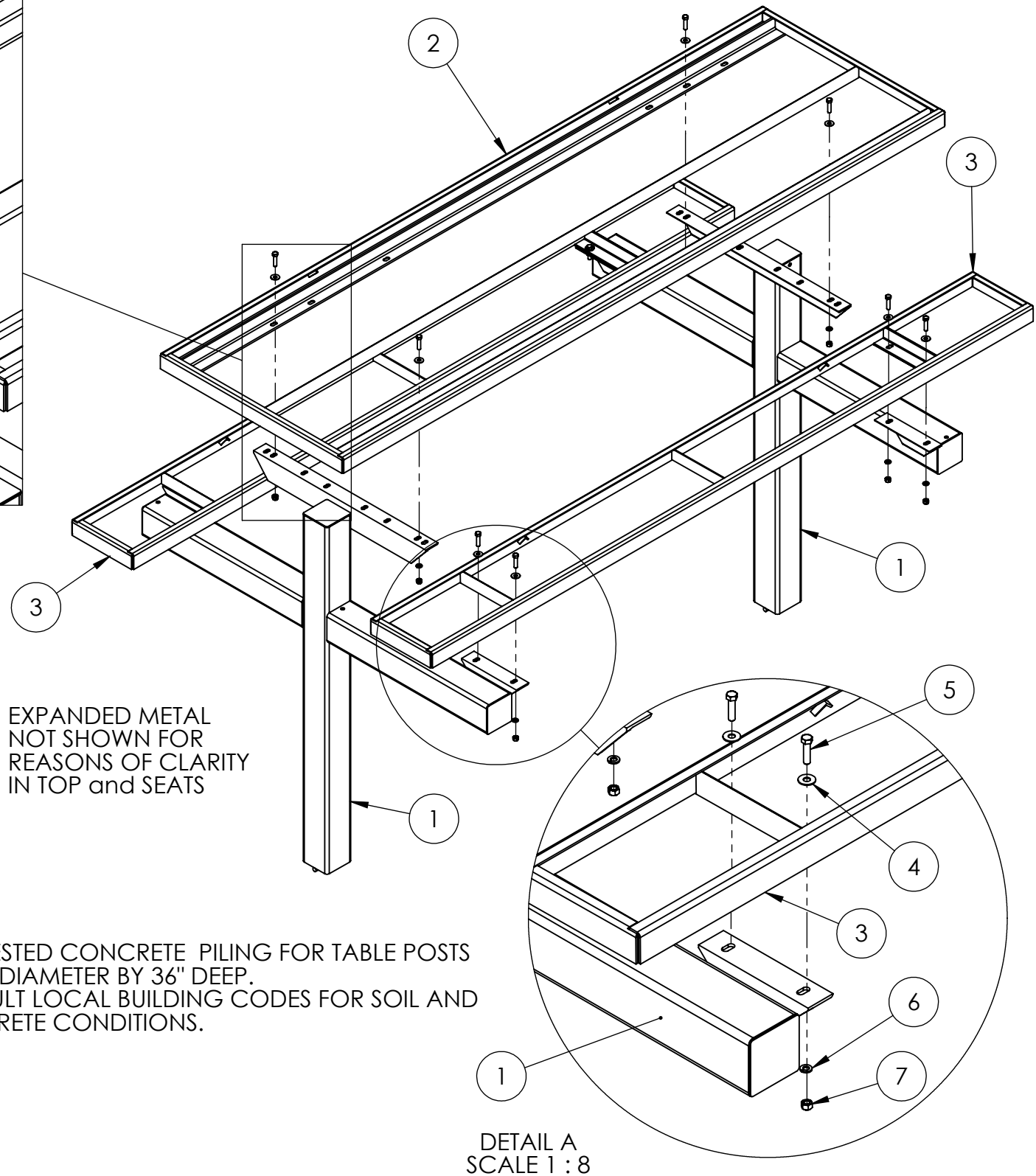
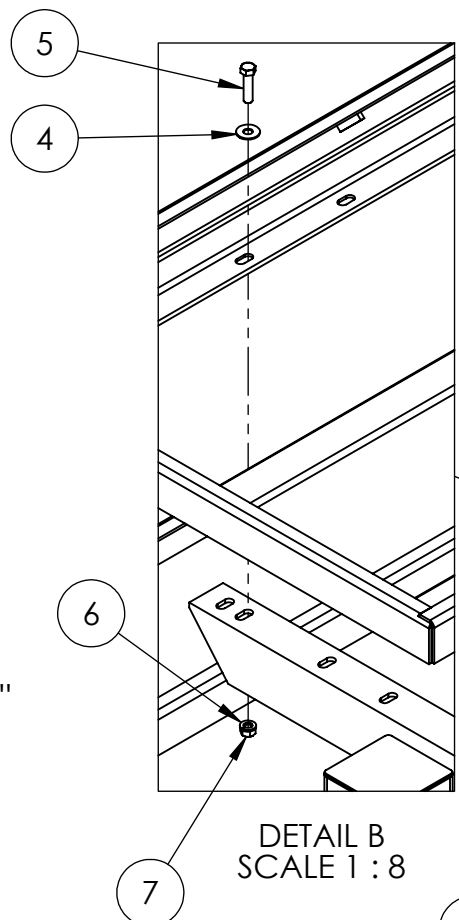
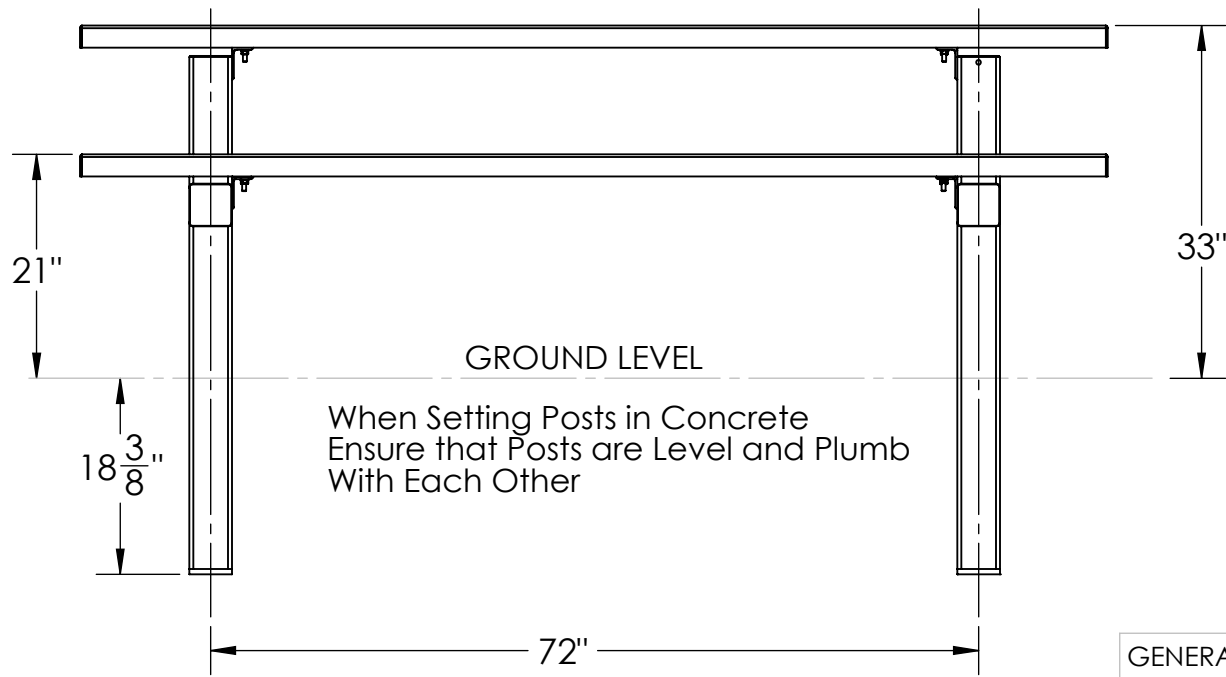
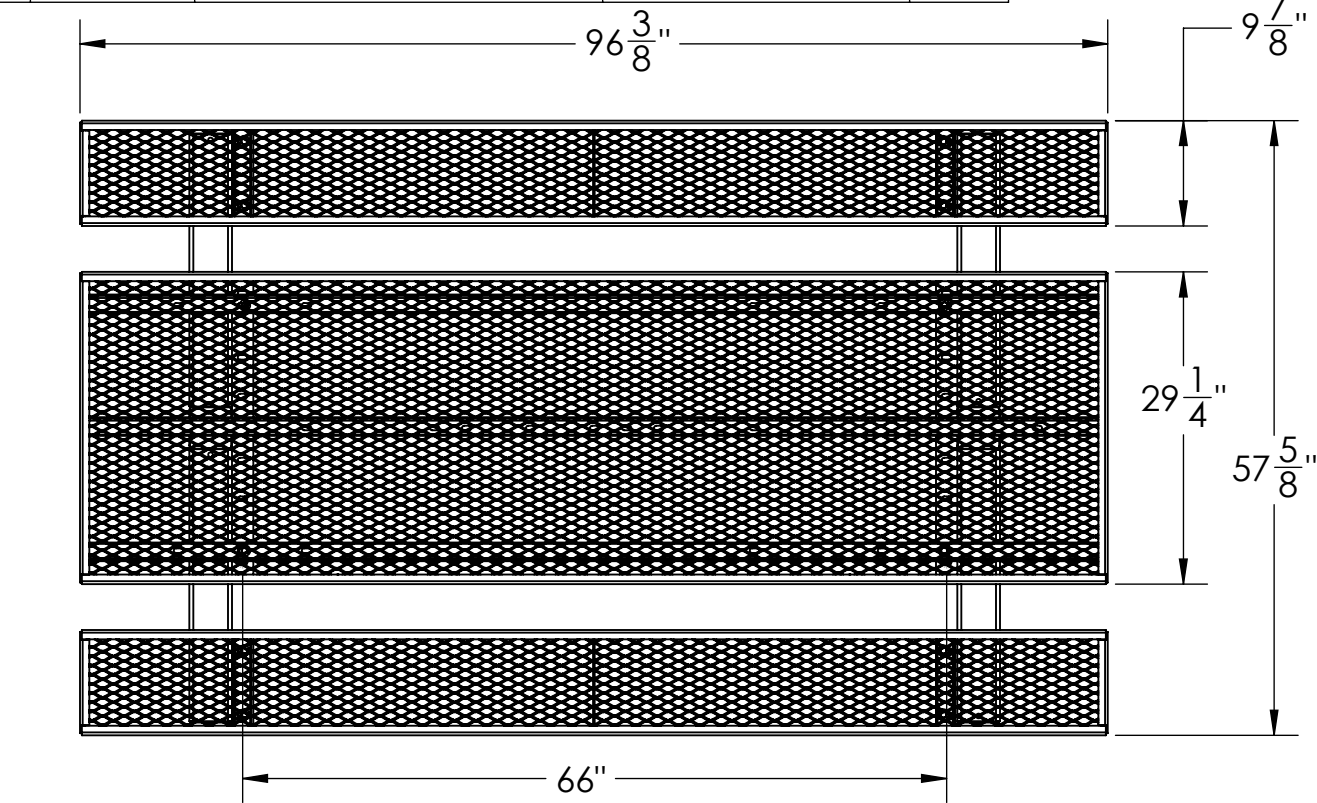

SUGGESTED CONCRETE PILING FOR TABLE POSTS OF 12" DIAMETER BY 36" DEEP. CONSULT LOCAL BUILDING CODES FOR SOIL AND CONCRETE CONDITIONS.

GENERAL NOTES		DIMENSIONS ARE IN INCHES TOLERANCES: LINEAR: $\pm 1/16$ ANGULAR: $\pm 1^\circ$		SHEET SIZE <b>B</b>		SCALE 1:32		REV		K Industries, Inc.	
<b>UNIT WEIGHT: 319.5 LBS.</b>		CONFIDENTIAL DRAWING. INFORMATION IS NOT TO BE COPIED OR DISCLOSED TO OTHERS WITHOUT CONSENT OF KAY INDUSTRIES. SPECIFICATIONS SUBJECT TO CHANGE WITHOUT NOTICE.		DRAWN BY		DAT		8/7/2017		DESC: 8FT TABLE VP TOP and SEATS IN GROUND DOUBLE POST	
				APPROVED						MATL:	
				LAST SAVED		davet		8/8/2017		<b>PART NO: 8DPTVP</b>	