

NO.	PART NUMBER	DESCRIPTION	QTY.
1	RT-31	UMBRELLA TUBE	1
2	RT-UMB	FIBERGLASS UMBRELLA	1
3	RT-SA4	RTR UMBRELLA SPIDER WELDMENT ASSY	1
4	RHSNBOLT 0.3125-18x2.25x2.25-N	5/16" x 2 1/4" CARRIAGE BOLT	4
5	NUT-5/16-18 Flanged Nut	5/16" FLANGED NUT	4

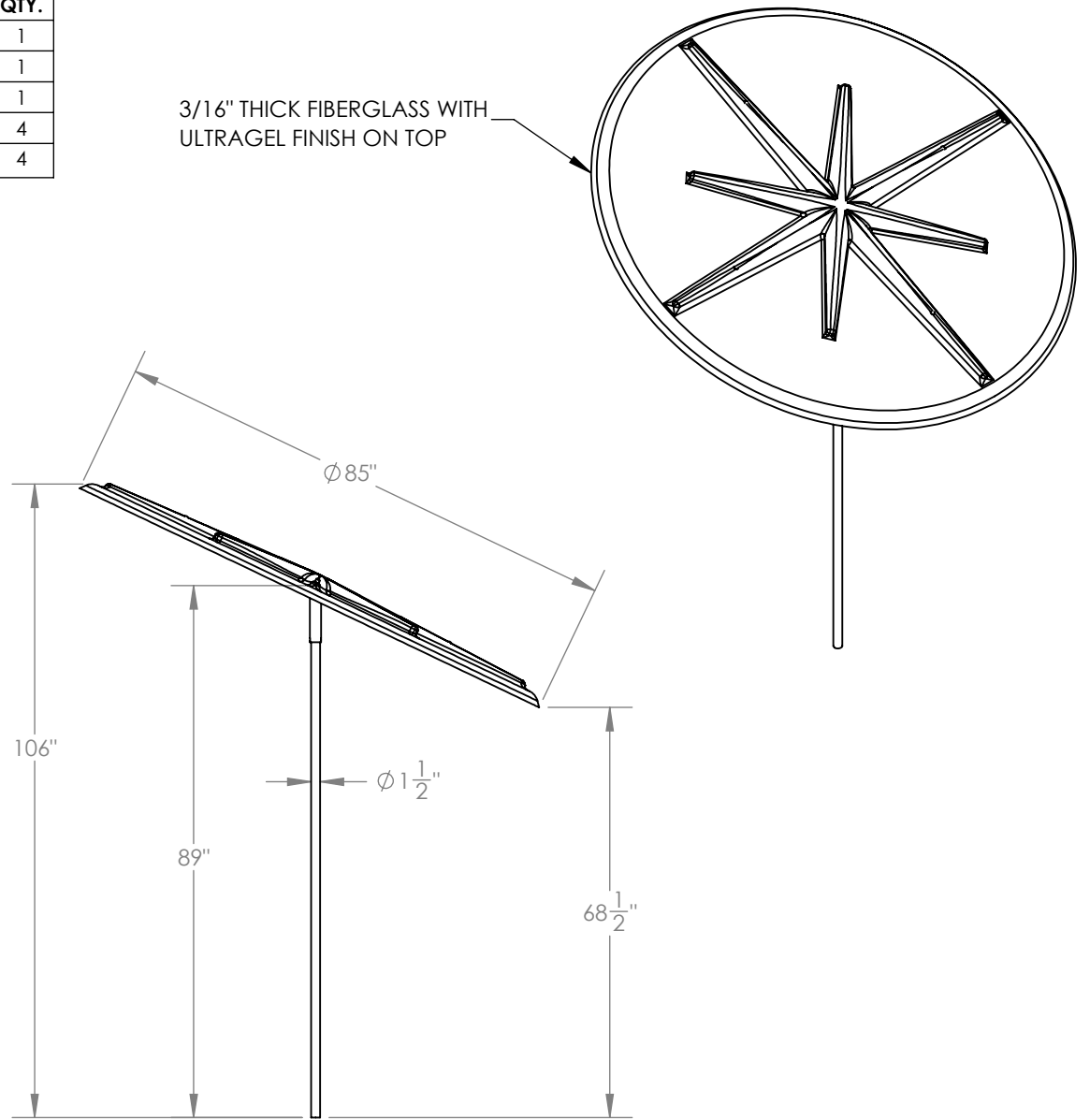
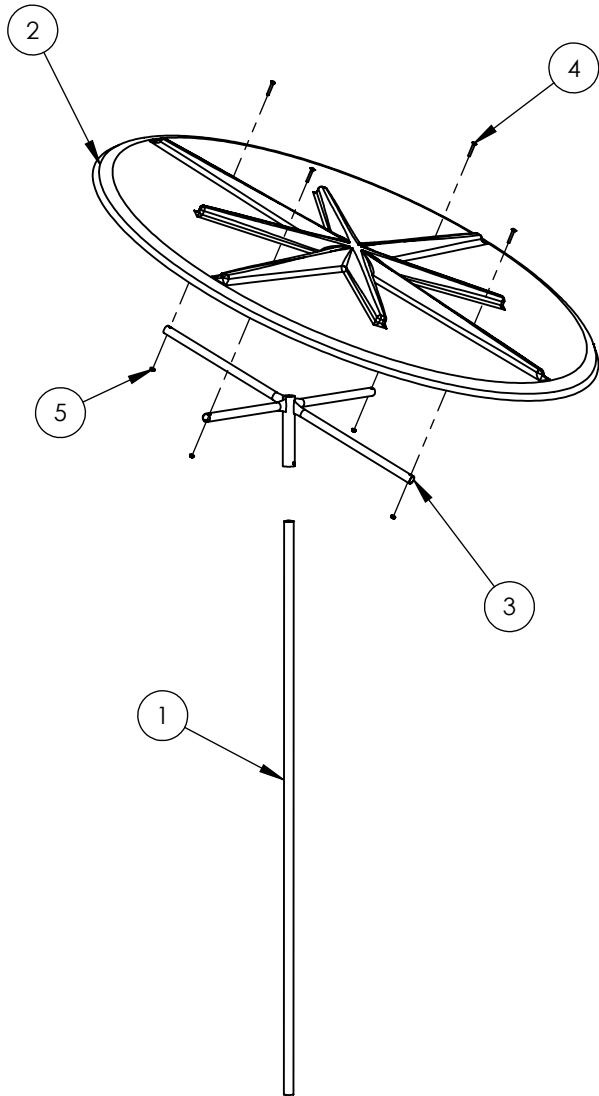

CONFIDENTIAL DRAWING. INFORMATION IS NOT TO BE COPIED OR DISCLOSED TO OTHERS WITHOUT CONSENT OF KAY PARK. SPECIFICATIONS SUBJECT TO CHANGE WITHOUT NOTICE.

MODEL NO: UF

DESC: FIBERGLASS UMBRELLA

DATE: 4/22/2019



Kay Park Rec.

SHEET 1 OF 1