

GENERAL NOTES

CONFIDENTIAL DRAWING.
 INFORMATION IS NOT TO BE COPIED OR
 DISCLOSED TO OTHERS WITHOUT
 CONSENT OF KAY INDUSTRIES.
 SPECIFICATIONS SUBJECT TO CHANGE
 WITHOUT NOTICE.

DIMENSIONS ARE IN INCHES
 TOLERANCES: LINEAR: ± 1/16
 ANGULAR: ± 1°

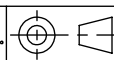

SHEET SIZE
B

SCALE
 1:16

REV



Kay Park Rec.

DRAWN BY

JNB

6/16/2017

DESC:

6' J2 TABLE WITH RP PLANKS

APPROVED

MATL:

LAST SAVED

chrisbull

3/6/2019

PART NO:

6J2GRRPCR

LEAVE ALL BOLTS LOOSE UNTIL ALL ARE IN PLACE.

1.) Place the top planks upside down on something that will not mark the surface of table . (Card Board or 2"x 4" Boards) as an example.

2. Place 3ea 2"x 10"x 6' PLANKS on this surface on the ground first as shown.

LEAVE ALL BOLTS LOOSE UNTIL ALL ARE IN PLACE.

3. Place one of the J2 LEG SUB ASSEMBLY on the predrilled holes. The top angle holes & leg spacer hole (for Table Brace) should face the center of the table, use the Hardware as shown in the DETAIL A

4. Place second of the J2 LEG SUB ASSEMBLY on the predrilled holes. The top angle holes & leg spacer hole (for Table Brace) should face the center of the table.

5. Place the CENTER CLEAT on the predrilled holes. The top channel holes & leg spacer hole (for Table Brace) should face the center of the table attach in the middle with 3/8"-16x 3" bolt

LEAVE ALL BOLTS LOOSE UNTIL ALL ARE IN PLACE.

6. Place the tube braces as shown in drawing view I and attach them as shown in DETAIL C.

7. Flip table at this point and place 2 seat planks on the Seat cleats of the Table legs and attach them as shown in DETAIL A

ITEM NO.	PART NUMBER	DESCRIPTION	QTY.
1	J2-SA1	J2 LEG WELDED SUB ASSEMBLY	2
2	6IRRP-7GR	2"x 10" 72" WITH GROOVE GRAY	2
3	6IPTRP5-7GR	RRP WITH GROOVE 72" GRAY	3
4	6IRP-48	REINFORCING BRACE	5
5	1PT-6	CJ & J2 CENTER CLEAT	1
6	6IPT-5	6IPT-5 GALV SUPPORT BRACE	2
7	RHBOLT 0.375-16x2.25x1-N		22
8	RHBOLT 0.375-16x3x1-N		1
9	RHBOLT 0.375-16x1x1-N		2
10	Preferred Wide FW 0.375	FLAT WASHER 3/8" WIDE	3
11	Regular LW 0.375	LOCK WASHER 3/8"	25
12	HNUOT 0.3750-16-D-N	3/8"-16 HEX NUT	25

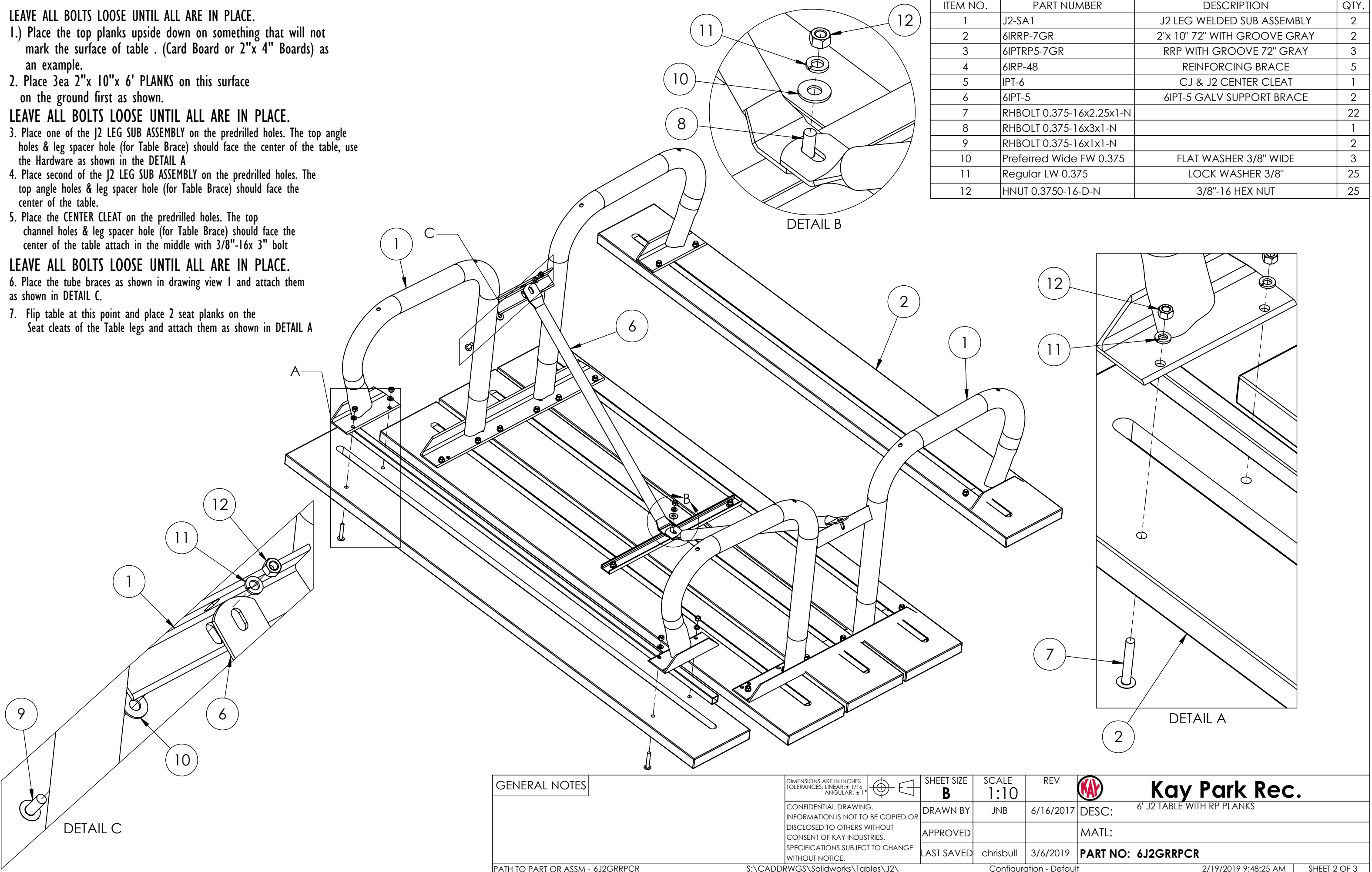

GENERAL NOTES

CONFIDENTIAL DRAWING.
 INFORMATION IS NOT TO BE COPIED OR
 DISCLOSED TO OTHERS WITHOUT
 CONSENT OF KAY INDUSTRIES.
 SPECIFICATIONS SUBJECT TO CHANGE
 WITHOUT NOTICE.

DIMENSIONS ARE IN INCHES
 TOLERANCES: LINEAR: ± 1/16
 ANGULAR: ± 1°

SHEET SIZE	SCALE	REV
B	1:10	
DRAWN BY	JNB	6/16/2017
APPROVED		
LAST SAVED	chrisbull	3/6/2019

Kay Park Rec.
 DESC: 6' J2 TABLE WITH RP PLANKS
 MATL:
PART NO: 6J2GRRPCR

ITEM NO.	PART NUMBER	DESCRIPTION	Default/ QTY.
1	J2-SA1	J2 LEG WELDED SUB ASSEMBLY	2
2	6IRRP-7GR	2"x 10" 72" WITH GROOVE GRAY	2
3	6IPTRP5-7GR	RRP WITH GROOVE 72" GRAY	3
4	6IRP-48	REINFORCING BRACE	5
5	IPT-6	CJ & J2 CENTER CLEAT	1
6	6IPT-5	6IPT-5 GALV SUPPORT BRACE	2

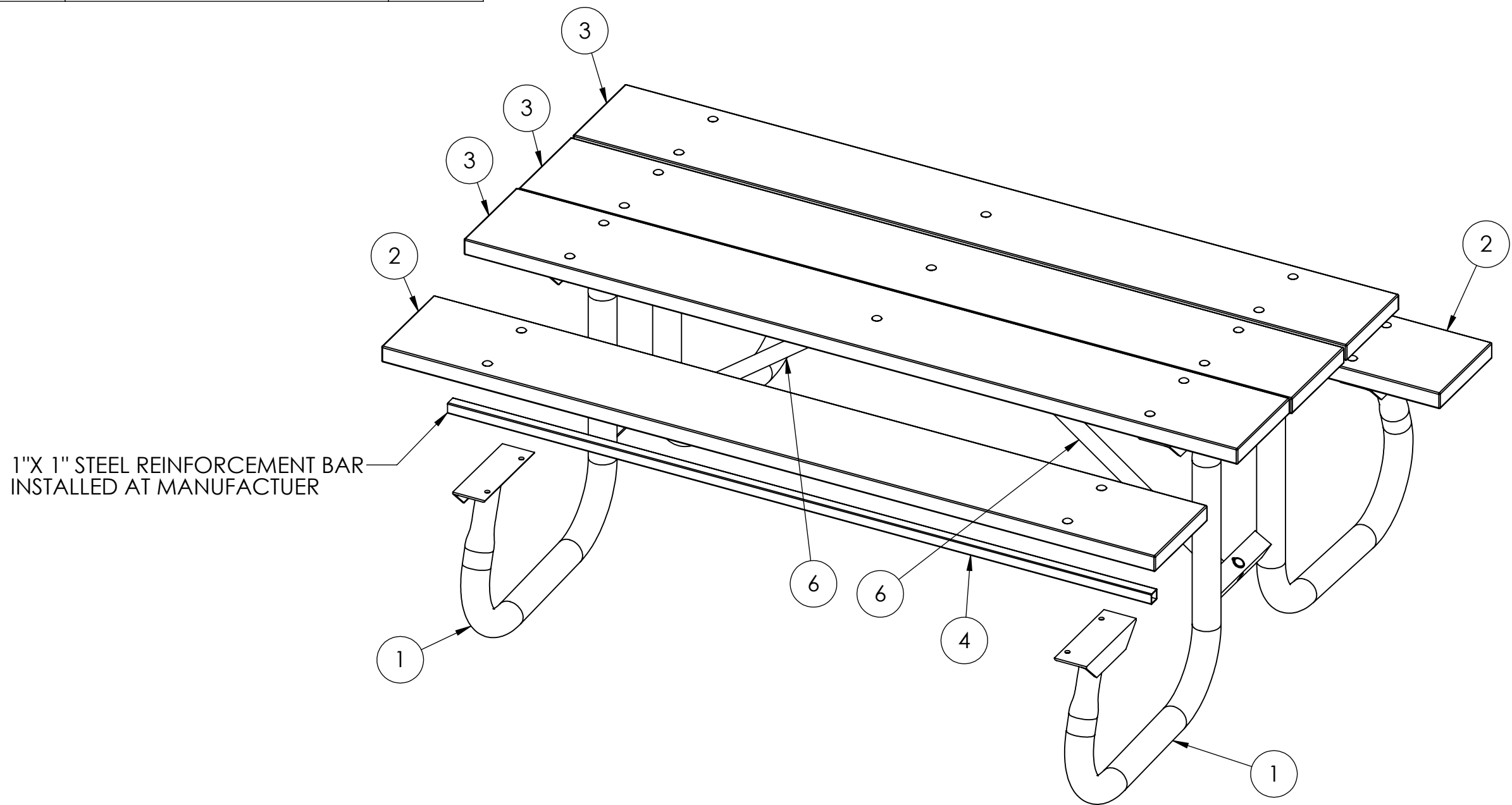

1"X 1" STEEL REINFORCEMENT BAR
INSTALLED AT MANUFACTUER

GENERAL NOTES	DIMENSIONS ARE IN INCHES TOLERANCES: LINEAR: $\pm 1/16$ ANGULAR: $\pm 1^\circ$		SHEET SIZE B	SCALE 1:10	REV		Kay Park Rec.
	CONFIDENTIAL DRAWING. INFORMATION IS NOT TO BE COPIED OR DISCLOSED TO OTHERS WITHOUT CONSENT OF KAY INDUSTRIES. SPECIFICATIONS SUBJECT TO CHANGE WITHOUT NOTICE.	DRAWN BY	JNB	6/16/2017	DESC:	6' J2 TABLE WITH RP PLANKS	
		APPROVED			MATL:		
		LAST SAVED	chrisbull	3/6/2019	PART NO: 6J2GRRPCR		
PATH TO PART OR ASSM - 6J2GRRPCR	S:\CADDRWGS\Solidworks\Tables\J2\	Configuration - Default	2/19/2019 9:48:25 AM	SHEET 3 OF 3			