

2 3/8" O.D. GALVANIZED HIGH TENSILE TUBE FOR LONGER LIFE.

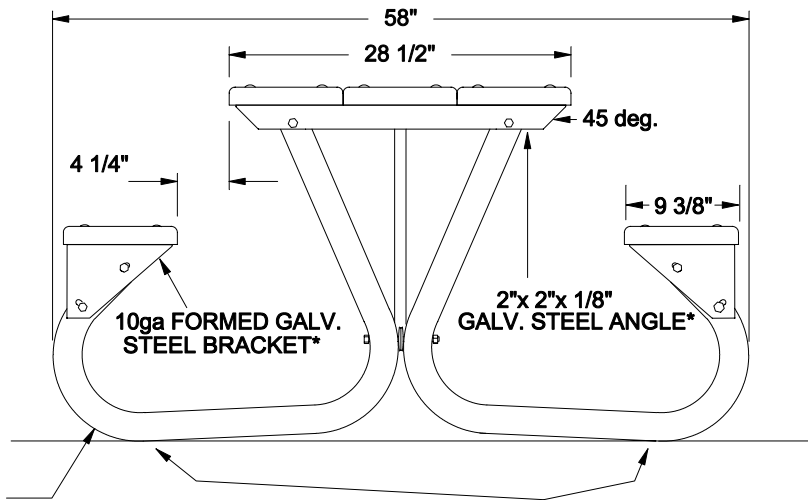

THE TABLE RESTS ON THE FOUR OUTSIDE CORNERS SO THAT IT WILL NOT ROCK ON UNEVEN GROUND.

\* SEAT BRACKET & TOP CLEAT ARE GALVANIZED AFTER FABRICATION TO ELIMINATE RAW EDGES LEFT WHEN USING PRE-GALV. SHEETS

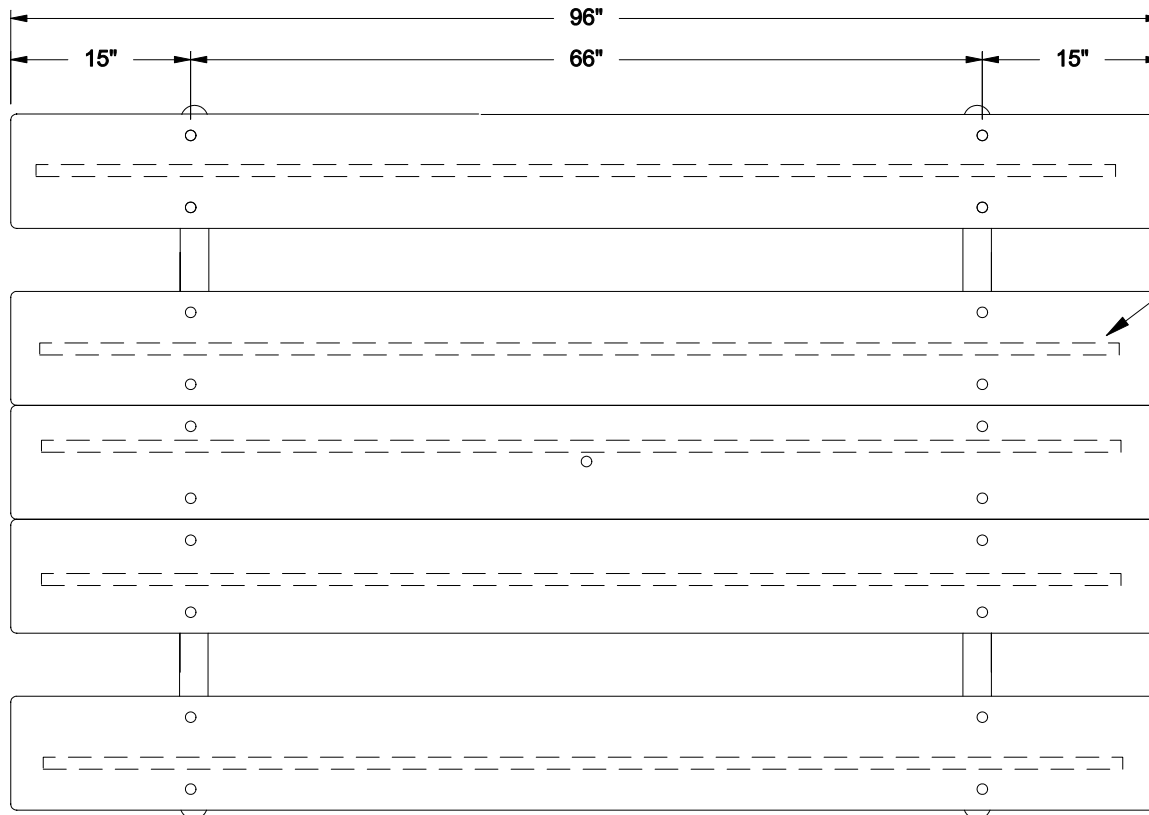

1"x 1" REINFORCING TUBE  
TOPS PLANKS HAVE ONE TUBE  
SEAT PLANKS HAVE TWO WELDED TOGETHER

2"x 10" No. Recycled Plastic  
WITH EASED EDGES

FILE NAME: 82BGRRP

# KAY PARK

MODEL	82BGRRP		WT.	386 lbs.
DRAWN BY	LCB	DATE	06/04	SCALE NONE