

1 5/16" O.D.  
GALVANIZED TUBE

2 3/8" O.D. GALVANIZED HIGH  
TENSILE TUBE FOR LONGER  
LIFE.

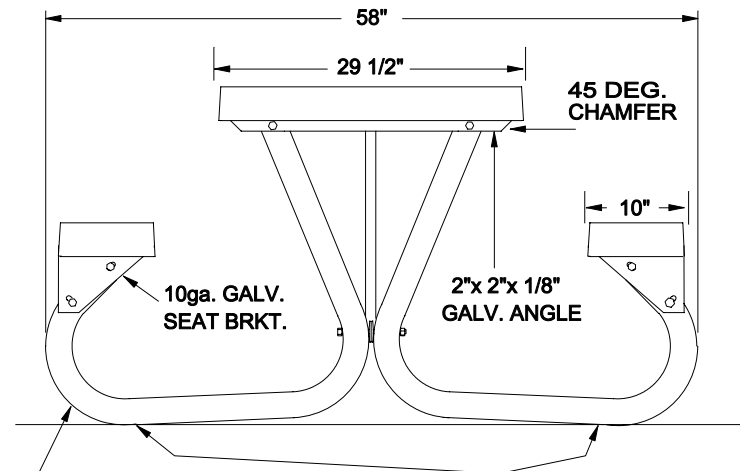

10ga. GALV.  
SEAT BRKT.

2"x 2"x 1/8"  
GALV. ANGLE

45 DEG.  
CHAMFER

THE TABLE RESTS ON THE FOUR OUTSIDE CORNERS  
SO THAT IT WILL NOT ROCK ON UNEVEN GROUND.

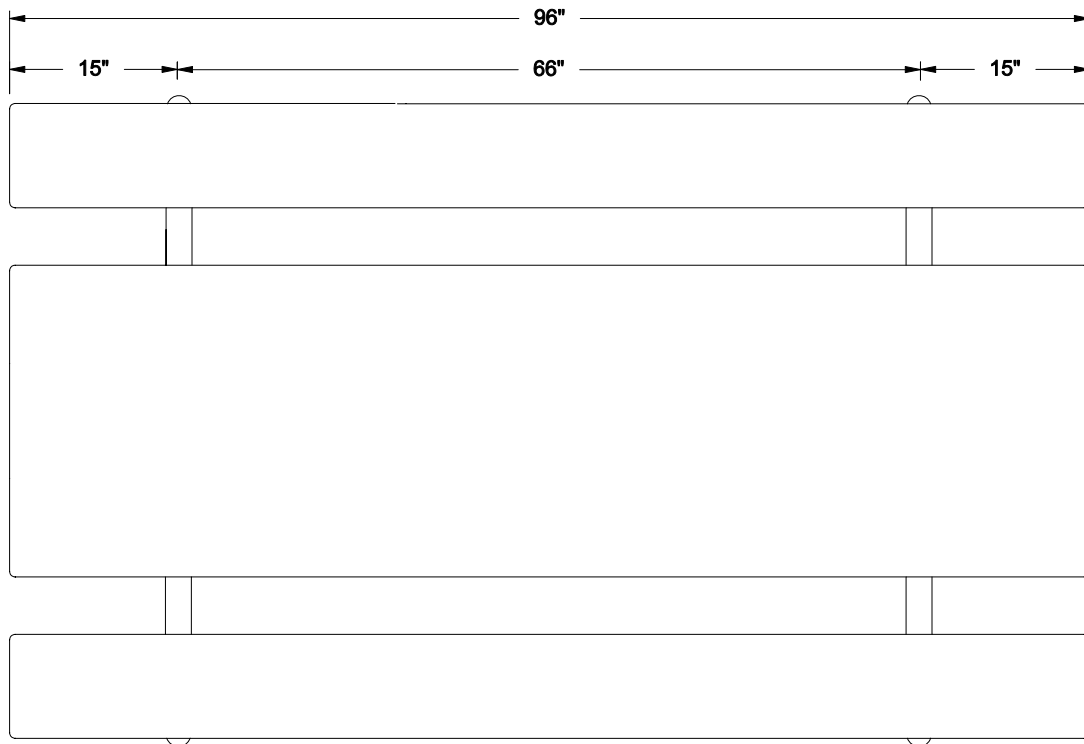

### CUT AWAY VIEW OF FIBERGLASS PLANK

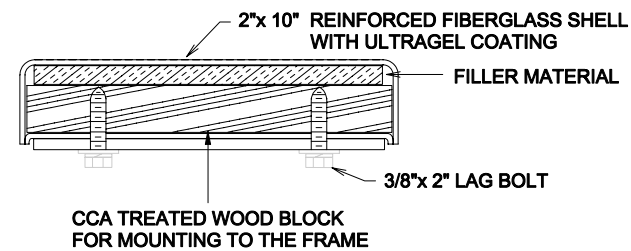

FIBERGLASS PLANK  
SEE DETAIL

# KAY PARK

MODEL	<b>82BGF</b>	WT.	<b>244 lbs.</b>
DRAWN BY	<b>LCB</b>	DATE	<b>2/27/98</b>
		SCALE	<b>NONE</b>

REV. 1/29/03, CHANGED TOP HEIGHT