

Bench legs are all steel and powder coated after fabrication.

The arm rests are welded to the sides of the outside frames.

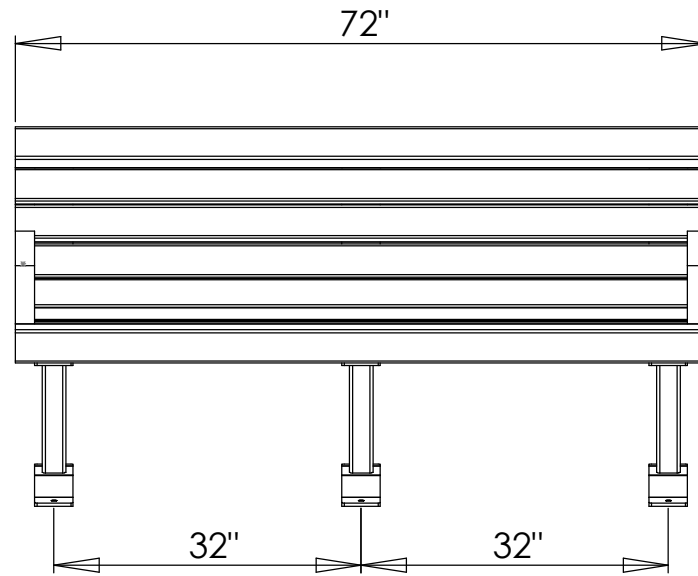
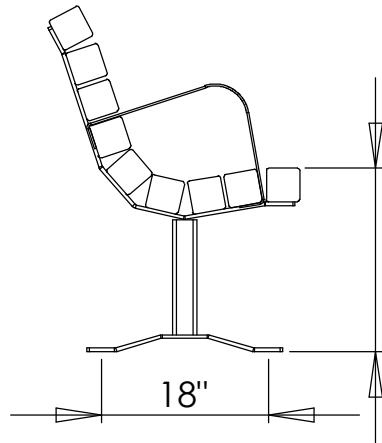

PROPRIETARY AND CONFIDENTIAL
 THE INFORMATION CONTAINED IN THIS DRAWING IS THE SOLE PROPERTY OF <INSERT COMPANY NAME HERE>. ANY REPRODUCTION IN PART OR AS A WHOLE WITHOUT THE WRITTEN PERMISSION OF <INSERT COMPANY NAME HERE> IS PROHIBITED.

		UNLESS OTHERWISE SPECIFIED:		NAME	DATE	
		DIMENSIONS ARE IN INCHES		DRAWN		TITLE: Contour Bench 4 x 4 Welded Arm Rest
		TOLERANCES:		CHECKED		
		FRACTIONAL ±		ENG APPR.		
		ANGULAR: MACH ± BEND ±		MFG APPR.		
		TWO PLACE DECIMAL ±		Q.A.		SIZE DWG. NO. REV
		THREE PLACE DECIMAL ±		COMMENTS:		
		INTERPRET GEOMETRIC TOLERANCING PER:				SCALE: 1:50 WEIGHT: SHEET 1 OF 1
		MATERIAL				
		FINISH				
NEXT ASSY	USED ON	APPLICATION	DO NOT SCALE DRAWING			