

1 5/16" O.D. GALV. HIGH TENSILE TUBE

2 3/8" O.D. GALVANIZED HIGH TENSILE TUBE FOR LONGER LIFE.

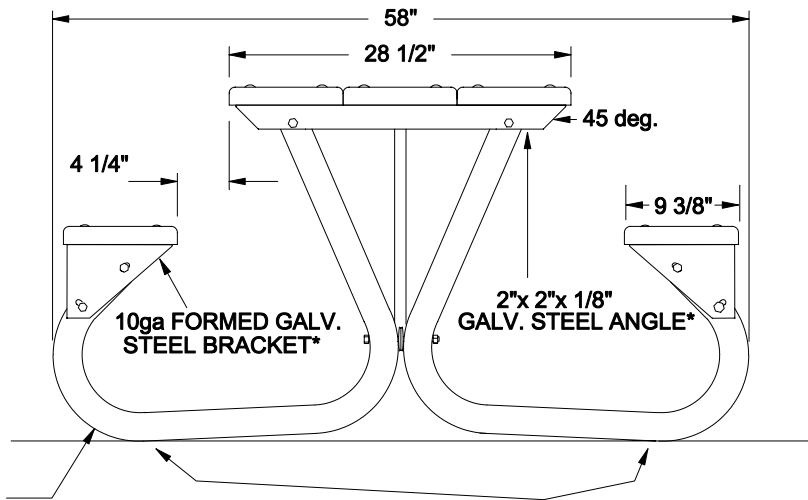

THE TABLE RESTS ON THE FOUR OUTSIDE CORNERS SO THAT IT WILL NOT ROCK ON UNEVEN GROUND.

* SEAT BRACKET & TOP CLEAT ARE GALVANIZED AFTER FABRICATION TO ELIMINATE RAW EDGES LEFT WHEN USING PRE-GALV. SHEETS

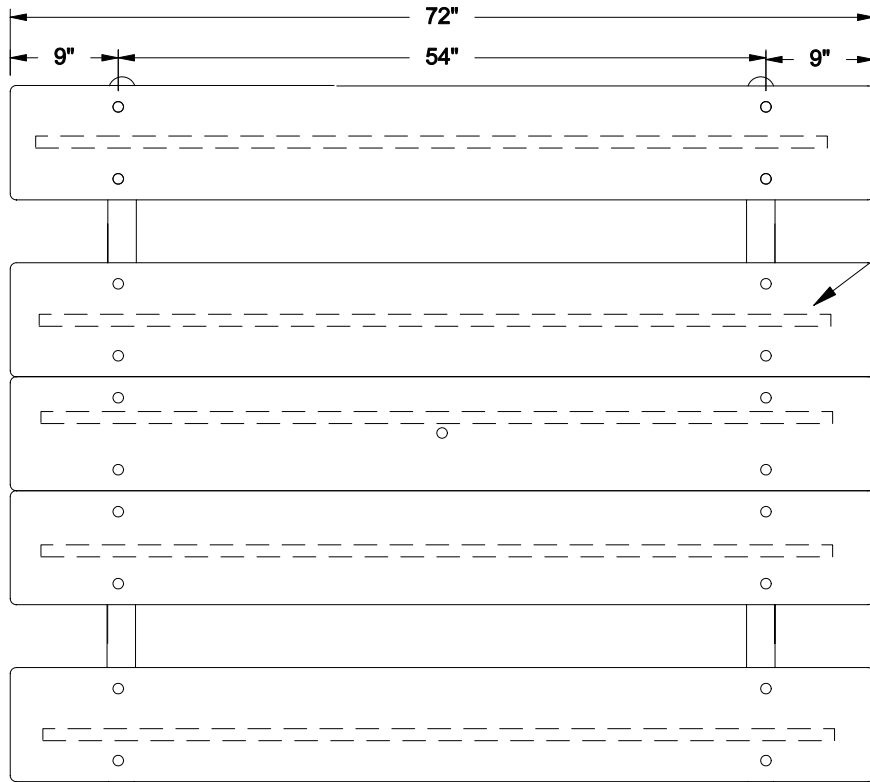

1"x 1" REINFORCING TUBE
TOPS PLANKS HAVE ONE TUBE
SEAT PLANKS HAVE TWO WELDED TOGETHER

2"x 10" No. Recycled Plastic WITH EASED EDGES

KAY PARK

MODEL	62BGRRP	WT.	296 lbs.
DRAWN BY	CKB	DATE	10/02
		SCALE	NONE