

Expanded Metal Top that has been Vinyl Coated

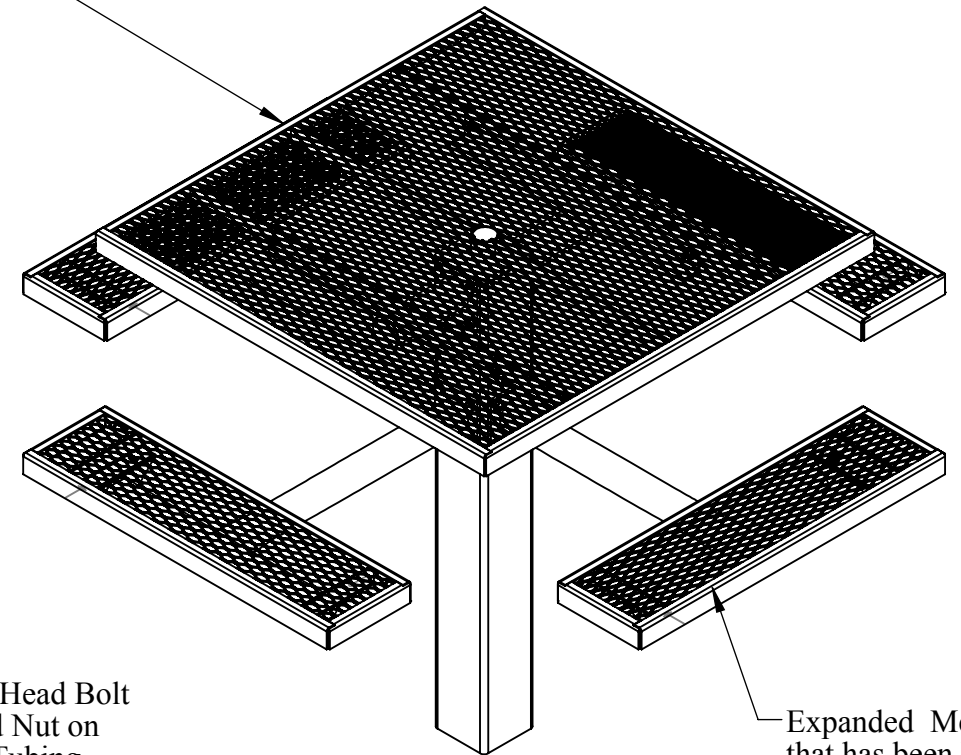

1/2"x 1 1/4" Hex Head Bolt with 1/2" Flanged Nut on the Inside of the Tubing

Expanded Metal Seat that has been Vinyl Coated

SECTION A-A  
SCALE 1 : 20

CONFIDENTIAL DRAWING AND INFORMATION IS NOT TO BE COPIED OR DISCLOSED TO OTHERS WITHOUT THE CONSENT OF KAY PARK. SPECIFICATIONS ARE SUBJECT TO CHANGE WITHOUT NOTICE.

GENERAL NOTES:		UNLESS OTHERWISE SPECIFIED:		NAME	DATE		TITLE: Kay Park Rec	
		DIMENSIONS ARE IN INCHES TOLERANCES: FRACTIONAL ± 1/32 BEND ± 1/2° THREE PLACE DECIMAL ± .005 Do Not Scale Drawing		DRAWN	DAT		6/18/2014	DESC. SINGLE POST SQUARE TABLE VINYL PLASTIC IN-GROUND
		MATERIAL		ENG APPR.			SIZE B	
				MFG APPR.			PART NO. 4SPTGVP	
				Last Saved	6/18/2014 4:28:02 PM		REV	
				COMMENTS:			Square In Ground (Frame)	
		SHEET 1 OF 2						
Path to Part or Assy - 4SPTGVP								

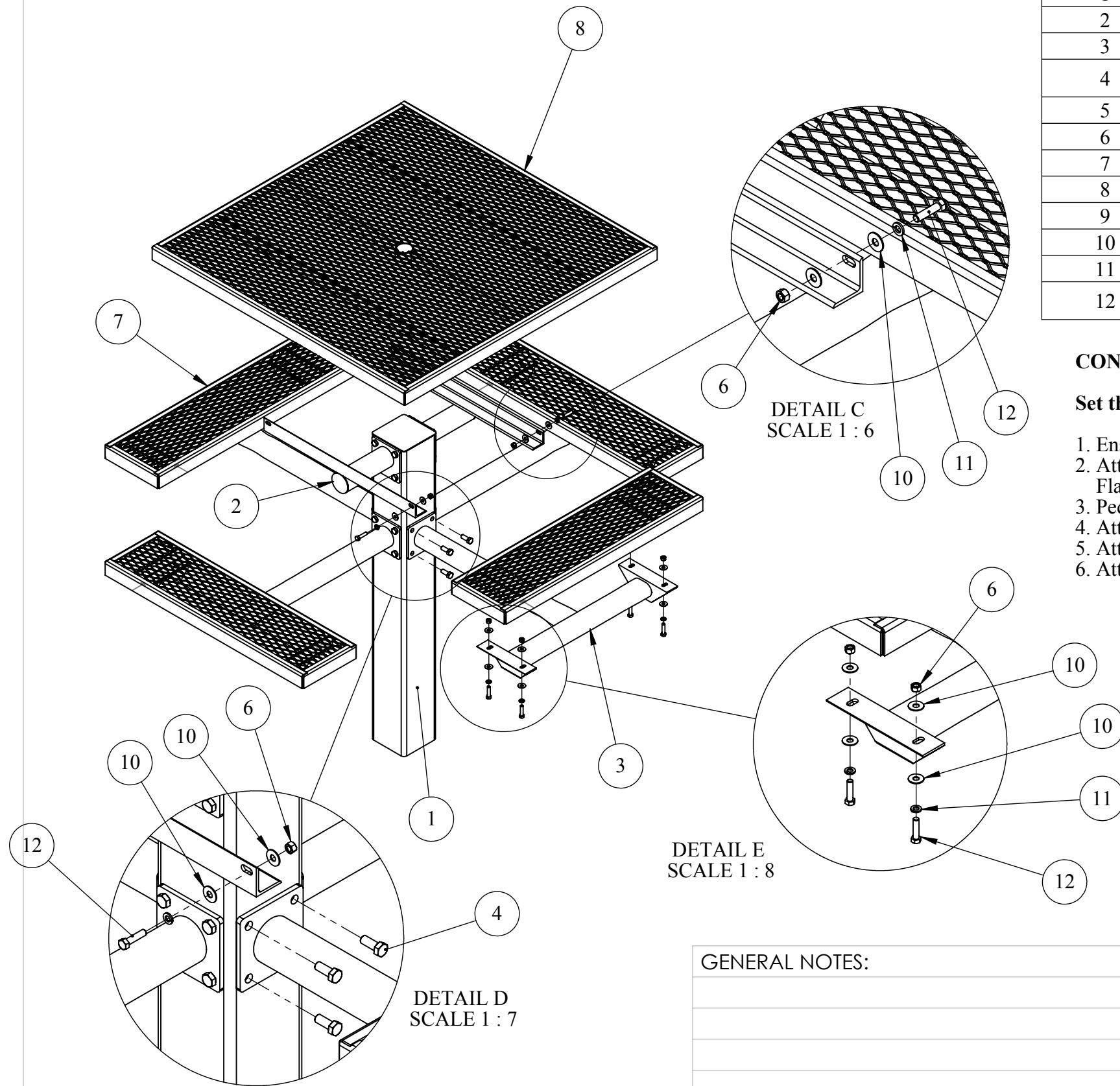

ITEM NO.	PART NUMBER	DESCRIPTION	Without Concrete Sono Tube/QTY.
1	4SPT-103	4SPT - PEDESTAL POST GALV	1
2	4SPT-SA1	4SPT VP TOP ARM ASSEMBLY GALV	2
3	4SPT-SA2	4SPT-SEAT ARM ASSEMBLY GALV	4
4	HFBOLT 0.5-13x1.25x1.25-N	1/2"-13x 1 1/4" HEX HEAD BOLT	24
5	HNUT 0.5000-13-D-N	1/2"-13 HEX NUT	24
6	HNUT 0.3750-16-D-N	3/8"-16 HEX NUT	20
7	3IV-8	3 Ft. VP SEAT	4
8	SQV-9	4 Ft. SQUARE VP TOP	1
9	ISPTC-SA5	PEDESTAL CAP ASSEMBLY PAINT	1
10	FLATW-3/8	FLAT WASHER 3/8"	40
11	LOCKW-3/8	LOCK WASHER 3/8"	20
12	HBOLT 0.3750-16x1.5x1-N	3/8"-16x 1 1/2" HEX HEAD BOLT	20

**CONSULT LOCAL BUILDING CODES FOR CONCRETE INSTALLATION SPECIFICATIONS**

**Set the Galvanized Pedestal Post in Concrete as Recommended**

1. Ensure that Pedestal Post is Plumb and Level Before the Concrete Starts to Set up.
2. Attach Lower Seat Arm Assemblies to Pedestal Post Using (4) 1/2" x 1/4" Hex Head Bolts, Flanged Nut will be Inside the Tube.
3. Pedestal Cap ISPTC-SA5 will Set On Top Pedestal Post Before Top Is Secured to Top Arm Assembly.
4. Attach Top Arm Assemblies Using (4) 1/2"x 1 1/4" Hex Head Bolt, Flanged Nut Will be Inside the Tube
5. Attach Vinyl Plastic Coated Top Assemblies with 3/8"x 2" Lag Bolts with Lock Washer Under the Head
6. Attach the Vinyl Plastic Coated Seats in the Same Manner as the Top.

CONFIDENTIAL DRAWING AND INFORMATION IS NOT TO BE COPIED OR DISCLOSED TO OTHERS WITHOUT THE CONSENT OF KAY PARK. SPECIFICATIONS ARE SUBJECT TO CHANGE WITHOUT NOTICE.

GENERAL NOTES:		UNLESS OTHERWISE SPECIFIED:	NAME	DATE	
DIMENSIONS ARE IN INCHES TOLERANCES: FRACTIONAL ± 1/32 BEND ± 1/2" THREE PLACE DECIMAL ± .005 Do Not Scale Drawing		DRAWN	DAT	6/18/2014	
		CHECKED			DESC.
		ENG APPR.			
		MFG APPR.			
		Last Saved	6/18/2014 4:28:02 PM		S:\CADDRWGS\Solidworks\Tables\SPT\Tables\
		COMMENTS:			
			SIZE	PART NO.	REV
			<b>B</b>	4SPTGVP	
Path to Part or Assy - 4SPTGVP		S:\CADDRWGS\Solidworks\Tables\SPT\Tables\			Without Concrete Sono Tube