

ITEM NO.	PART NUMBER	DESCRIPTION	Fiberglass Top and Seats/QTY.
1	SQ-SA2	SQUARE SPIDER SUB ASSY	1
2	SQ-66	SQ. TOP ATTACHMENT ANGLE	4
3	4SQF-9	48" x 48" SQUARE FIBERGLASS TOP	1
4	RTR-SA1	1 5/8" RTR LEG ASSEMBLY	8
5	SQAW-2	TOP TABLE CLEAT	2
6	No Notch	3' FIBERGLASS SEAT	4
7	Regular FW 0.375	3/8" REGULAR FLAT WASHER	24
8	HLSCREW 0.3750x2	3/8" HEX HEADx 1 1/4" LAG SCREW	24
9	HBOLT 0.3750-16x3x1-N	HEX HEAD BOLT 3/8"-16x 3"	4
10	HBOLT 0.3750-16x2.5x1-N	HEX HEAD BOLT 3/8"-16x 2 1/2"	12
11	Regular LW 0.375	3/8" REG LOCK WASHER	16
12	HNUT 0.3750-16-D-N	HEX NUT 3/8"-16	16

1. Place the Table Top Upside Down on a Relatively Flat Surface Such as the Corrugated Card Board that the Product Came in.
2. Assemble the Table Legs as Shown in **DETAIL A**, Make Sure the 3" Long Hex Head Bolt is Used Where the Slots Line Up. Finger Tighten the Bolts and Nuts at This Time.
3. Next Attach the Spider Cross Bracing to the Bottom Part of the Legs. Start with One Corner Using the 3/8"-16x 2 1/2" Hex Head Bolts, Washers, Lock Washers, and Nuts. Go to the Opposite Corner and Insert That Hardware. Do the same Procedure on the Other Set of Legs. Finger Tighten Hardware. **SEE DETAIL B**
4. Tighten the Nuts and Bolts that are Close to the Table Top First, Make Sure the Legs are Straight Up and Down. Tighten the Nuts and Bolts on the Cross Bracing Next.
5. Turn the Table Right Side Up to Attach the Seats to the Seat Brackets.
SEE SHEET 2 for DETAILS

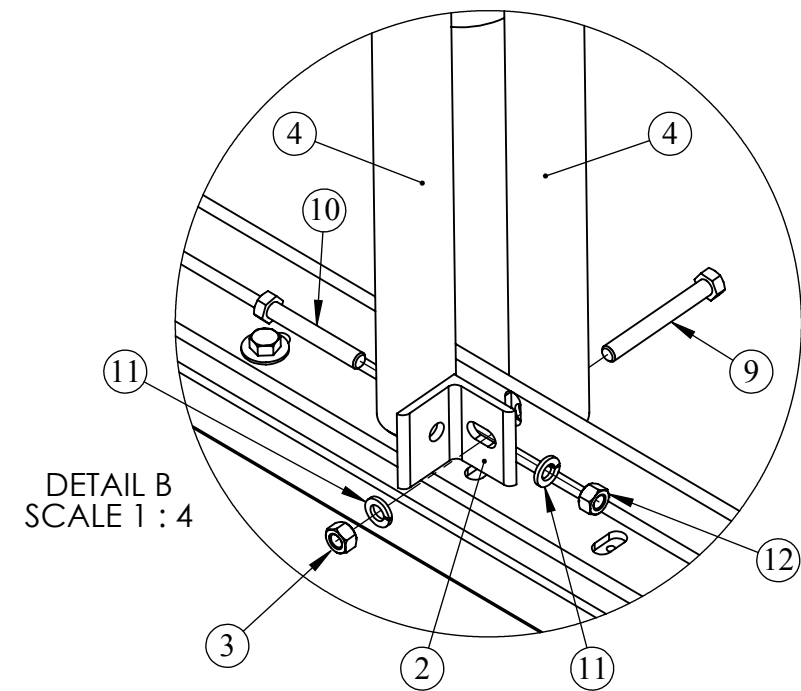
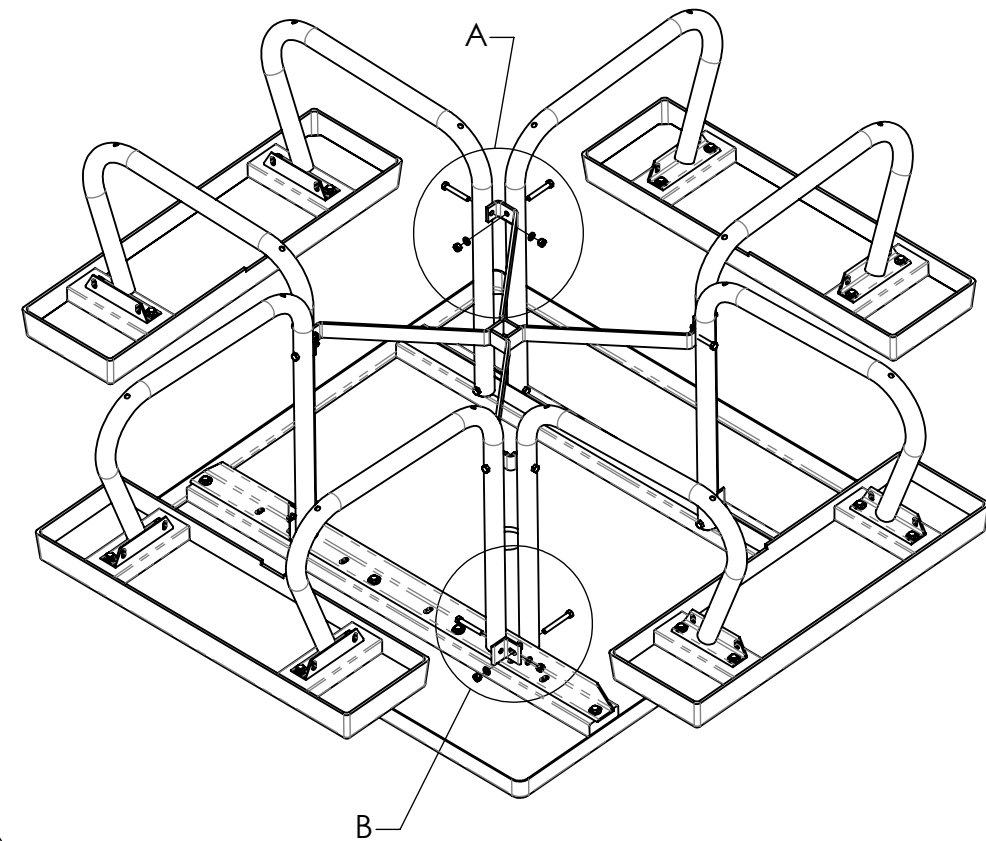
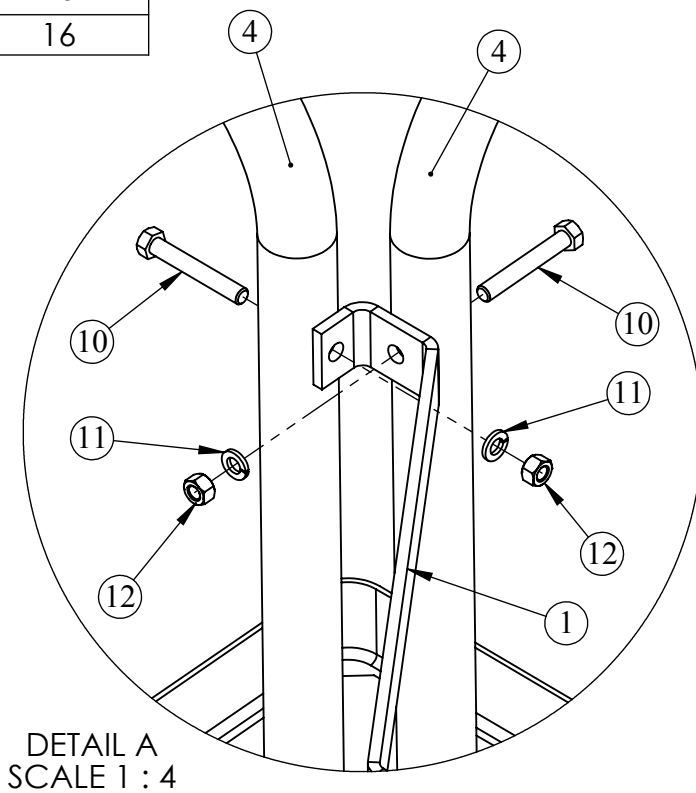

Confidential Drawing and Information is Not to be Copied or Disclosed to Others Without the Consent of Kay Industries. Specifications Are Subject to Change Without Notice.

GENERAL NOTES:		UNLESS OTHERWISE SPECIFIED:		NAME	DATE	K Industries, Inc.			
DO NOT SCALE DRAWING		DIMENSIONS ARE IN INCHES		DRAWN	DAT	4/5/2016	TITLE:		
		TOLERANCES:		CHECKED			DESC. 4' SQUARE TABLE FIBER GLASS TOP and SEATS		
		FRACTIONAL ± 1/32		ENG APPR.			S:\CADDRWGS\Solidworks\Tables\SJ\		
		BEND ± 1/2°		MFG APPR.			SIZE	PART NO. 4SJCF	REV
		THREE PLACE DECIMAL ± .005		COMMENTS:			B		
MATERIAL		Last Saved	4/5/2016 11:21:42 AM						
SHEET 1 OF 2									

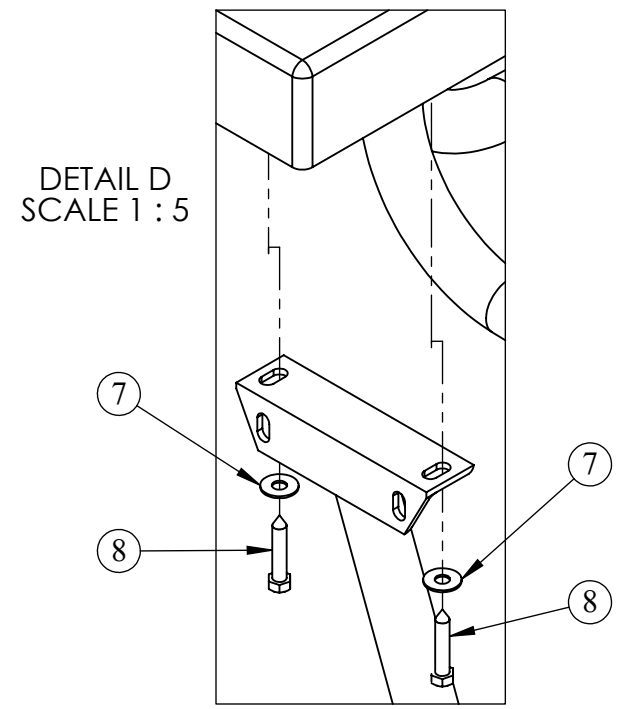
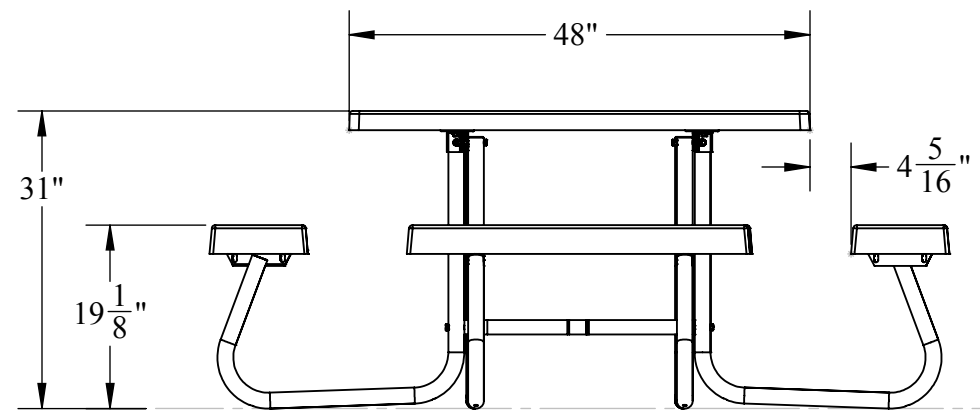
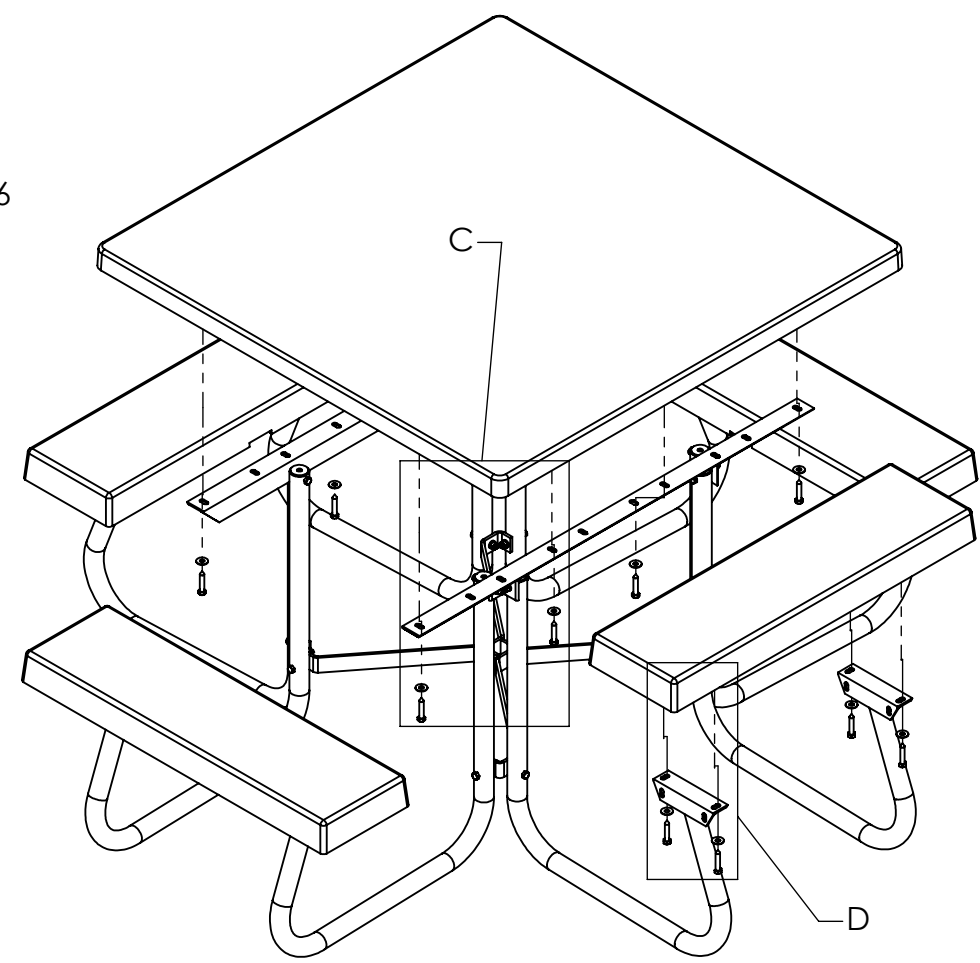
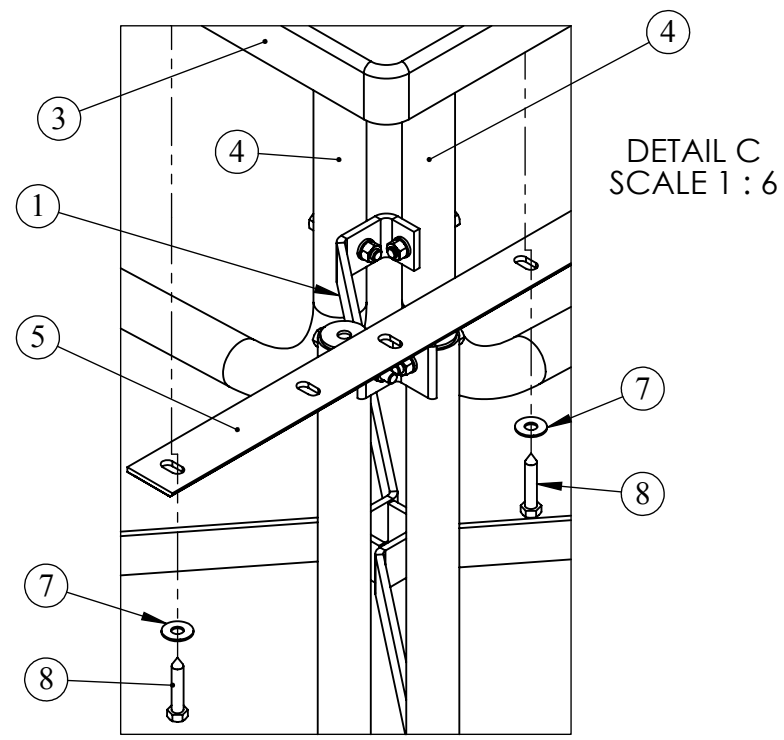
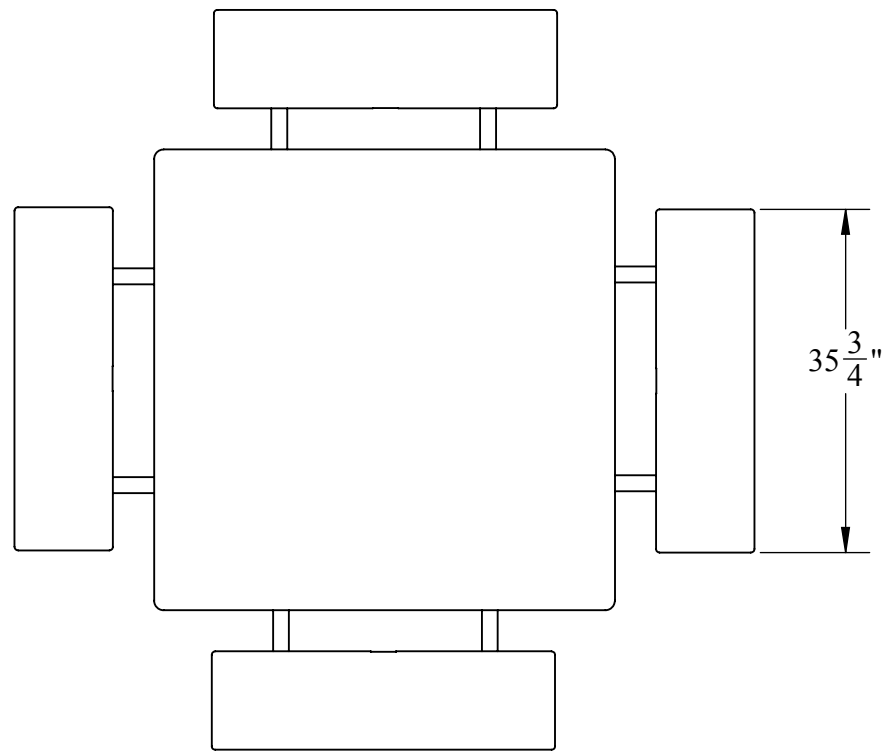

ITEM NO.	PART NUMBER	DESCRIPTION	QTY.
1	SQ-SA2	SQUARE SPIDER SUB ASSY	1
2	SQ-66	SQ. TOP ATTACHMENT ANGLE	4
3	4SQF-9	48" x 48" SQUARE FIBERGLASS TOP	1
4	RTR-SA1	1 5/8" RTR LEG ASSEMBLY	8
5	SQAW-2	TOP TABLE CLEAT	2
6	No Notch	3' FIBERGLASS SEAT	4
7	Regular FW 0.375	3/8" REGULAR FLAT WASHER	24
8	HLSCREW 0.3750x2	3/8" HEX HEADx 1 1/4" LAG SCREW	24
9	HBOLT 0.3750-16x3x1-N	HEX HEAD BOLT 3/8"-16x 3"	4
10	HBOLT 0.3750-16x2.5x1-N	HEX HEAD BOLT 3/8"-16x 2 1/2"	12
11	Regular LW 0.375	3/8" REG LOCK WASHER	16
12	HNUIT 0.3750-16-D-N	HEX NUT 3/8"-16	16

GENERAL NOTES:	UNLESS OTHERWISE SPECIFIED:	NAME	DATE			
	DIMENSIONS ARE IN INCHES	DRAWN	4/5/2016			
	TOLERANCES:	CHECKED		TITLE:		
	FRACTIONAL ± 1/32	ENG APPR.		DESC.		
	BEND ± 1/2°	MFG APPR.		S:\CADDWGS\Solidworks\Tables\SJ\		
THREE PLACE DECIMAL ± .005	DO NOT SCALE DRAWING	Last Saved	4/5/2016 11:21:42 AM	SIZE	PART NO.	REV
MATERIAL		COMMENTS:		B	4SJCF	
				SHEET 2 OF 2		

Confidential Drawing and Information
is Not to be Copied or Disclosed to Others
Without the Consent of Kay Industries.
Specifications Are Subject to Change
Without Notice.