

ITEM NO.	PART NUMBER	DESCRIPTION	Rev 0/QTY.
1	12CJL-5	12CJ DOUBLE BEND BRACE 38"	1
2	12CJS-5	12CJ 1 BEND BRACE (3/TBL)	3
3	12IPT8-7	2x10 12' 8 HOLE SYP TOP (60")	3
4	12IW6-7	2x10 12' 6 HOLE SYP SEAT (60")	2
5	CARR-3/8x214	GARRIGE BOLT 3/8" x 2 1/4"	34
6	CARR-3/8X3	CARRIAGE BOLT 3/8" x 3"	2
7	CJ-SA1	CJ LEG SUB ASSY	3
8	FLATW-3/8	FLAT WASHER 3/8"	5
9	IPTC-6	COATED CENTER CLEAT	2
10	LOCKW-3/8	LOCK WASHER 3/8"	39
11	NUT-3/8	NUT 3/8"	39
12	HEX-3/8x1	HEX BOLT 3/8" x 1"	2
13	HEX-3/8X112	HEX BOLT 3/8" x 1 1/2"	1

CARE & MAINTENANCE FOR KAY PARK

Tables periodically (at least once a year) check to make sure all bolts and nuts are in place and tight. Replacement parts may be purchased by calling Kay Park-Rec Corp. at 1-800-553-2476.

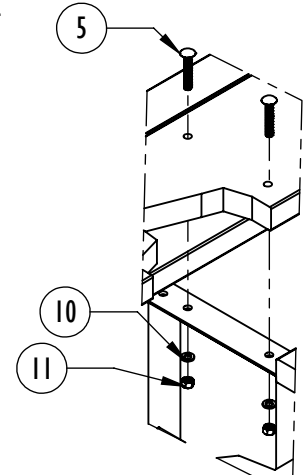
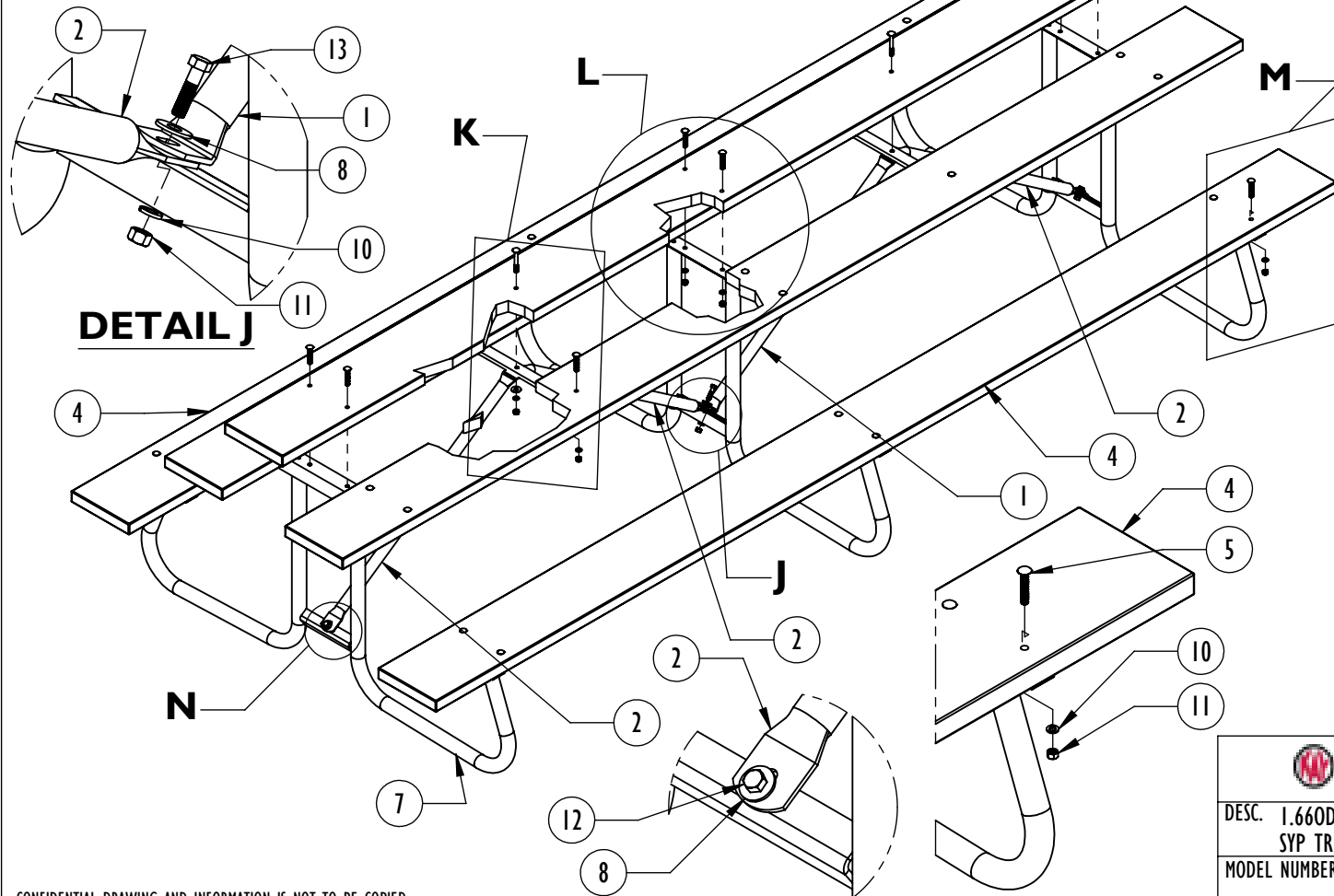

DETAIL L

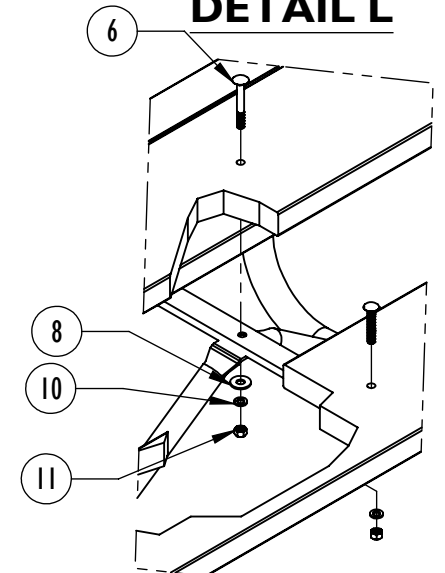

DETAIL K

CONFIDENTIAL DRAWING AND INFORMATION IS NOT TO BE COPIED OR DISCLOSED TO OTHERS WITHOUT THE CONSENT OF KAY PARK. SPECIFICATIONS ARE SUBJECT TO CHANGE WITHOUT NOTICE.

		Kay Park Rec	
DESC. 1.660D SCH 40 HOT DIPPED GALV. TABLE FRAME W/ 12' 2x10 SYP TREATED PLANK			
MODEL NUMBER. 12CJGW		WT.	
DRAWN BY PAVEL	DATE 2/18/2013	Sheet 1 of 3	SCALE NONE

LEAVE ALL BOLTS LOOSE UNTIL ALL ARE IN PLACE.

- 1.) Place the top upside down on something that will not mark the surface of table .
2. Place 3ea SYP TREATED 8' x 2" 10" PLANKS on the surface which you apply on the ground first as shown.
3. Insert carriage bolts into the hole as shown.

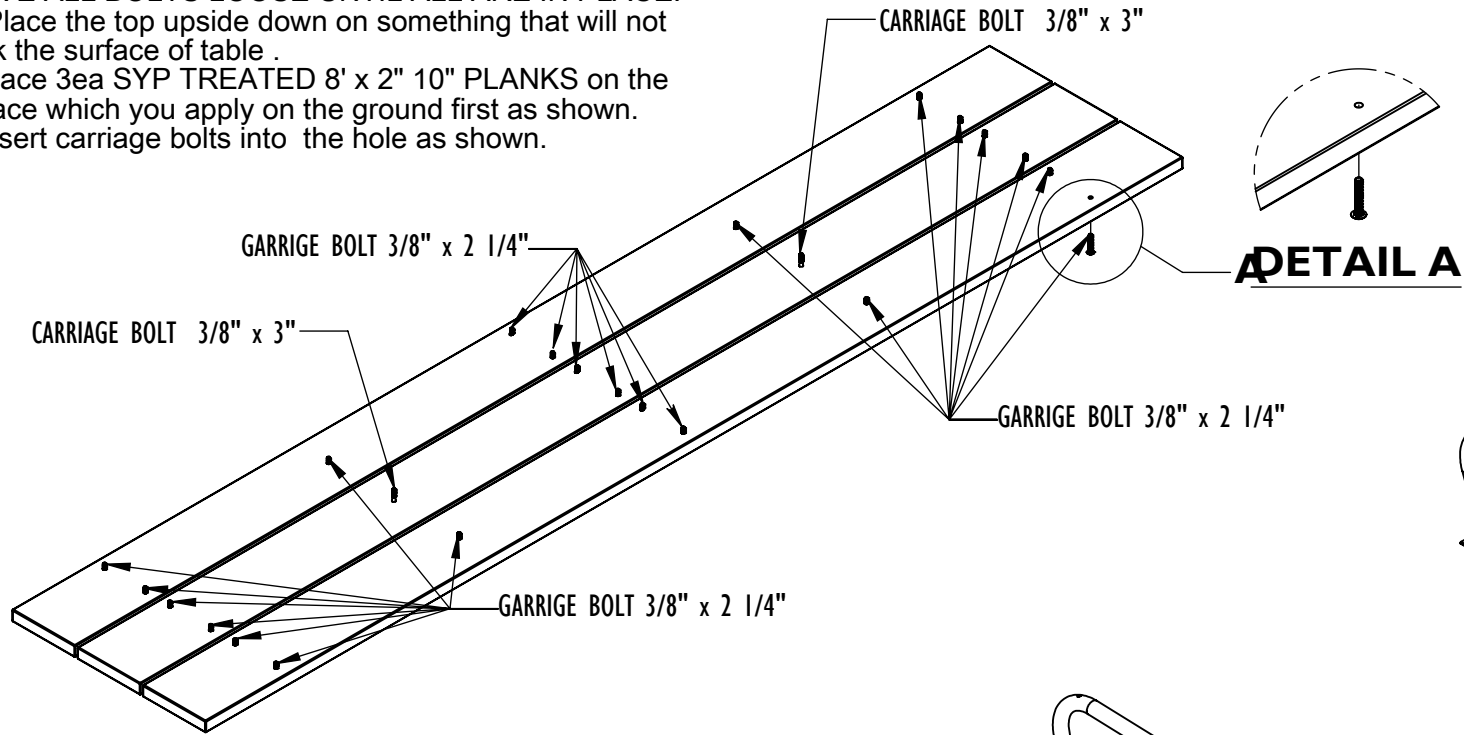

4. Place (3ea) of the CJ LEG SUB ASSEMBLY into the predrilled holes. The top angle holes & leg spacer hole (for Table Brace) should face the center of the table, use (18ea) 3/8" lock washer and (18ea) 3/8" Nuts as shown.

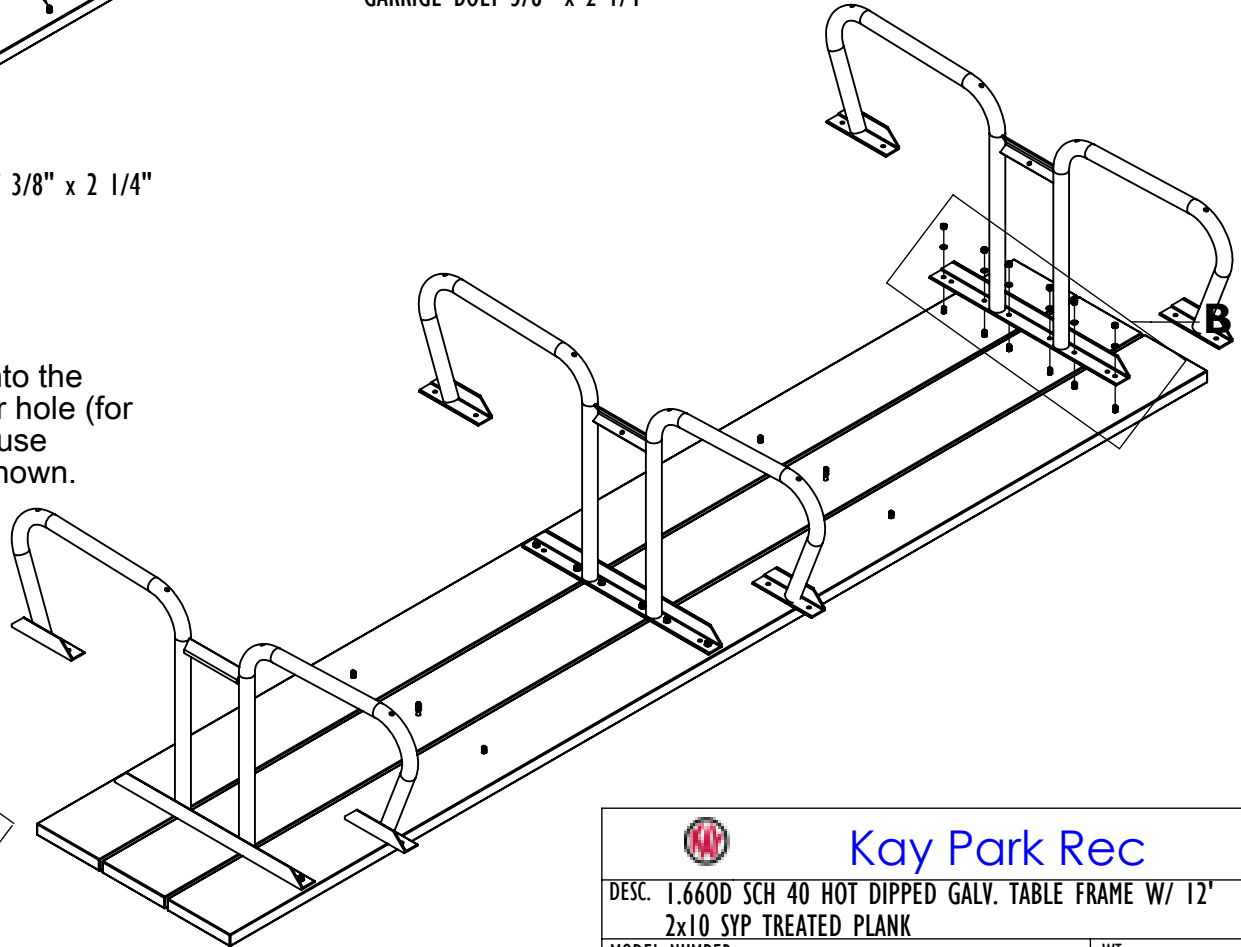
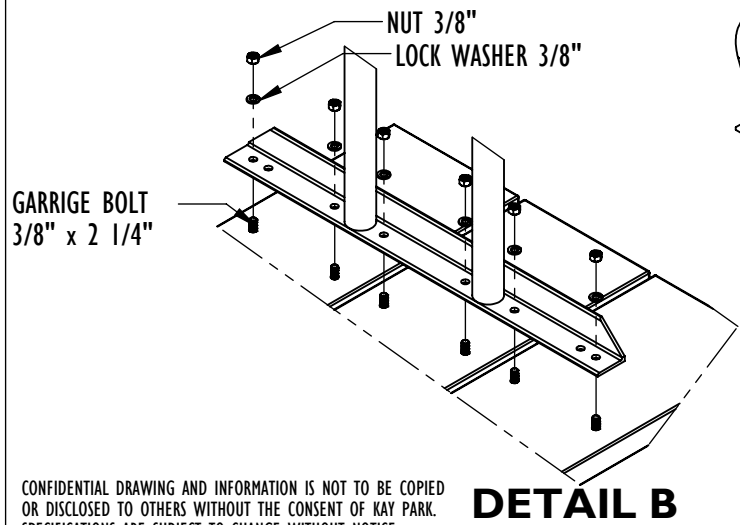

CONFIDENTIAL DRAWING AND INFORMATION IS NOT TO BE COPIED OR DISCLOSED TO OTHERS WITHOUT THE CONSENT OF KAY PARK. SPECIFICATIONS ARE SUBJECT TO CHANGE WITHOUT NOTICE.

DETAIL B

		Kay Park Rec	
DESC. 1.660D SCH 40 HOT DIPPED GALV. TABLE FRAME W/ 12' 2x10 SYP TREATED PLANK			
MODEL NUMBER. 12CJGW			WT.
DRAWN BY PAVEL	DATE 2/18/2013	Sheet 1 of 3	SCALE NONE

LEAVE ALL BOLTS LOOSE UNTIL ALL ARE IN PLACE.

5. Place 2ea of the CENTER CLEAT on the predrilled holes. The top channel holes & leg spacer hole (for Table Brace) should face the center of the table, use (4ea)3/8"lockwasher and (4ea) 3/8"Nuts as shown.

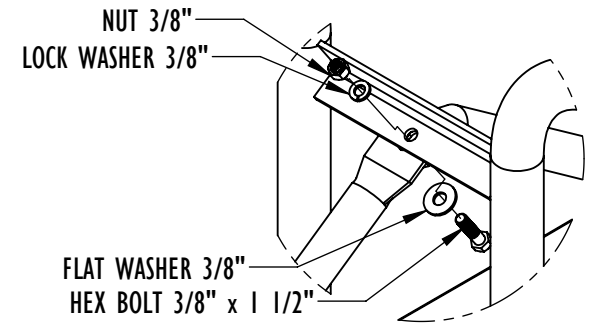
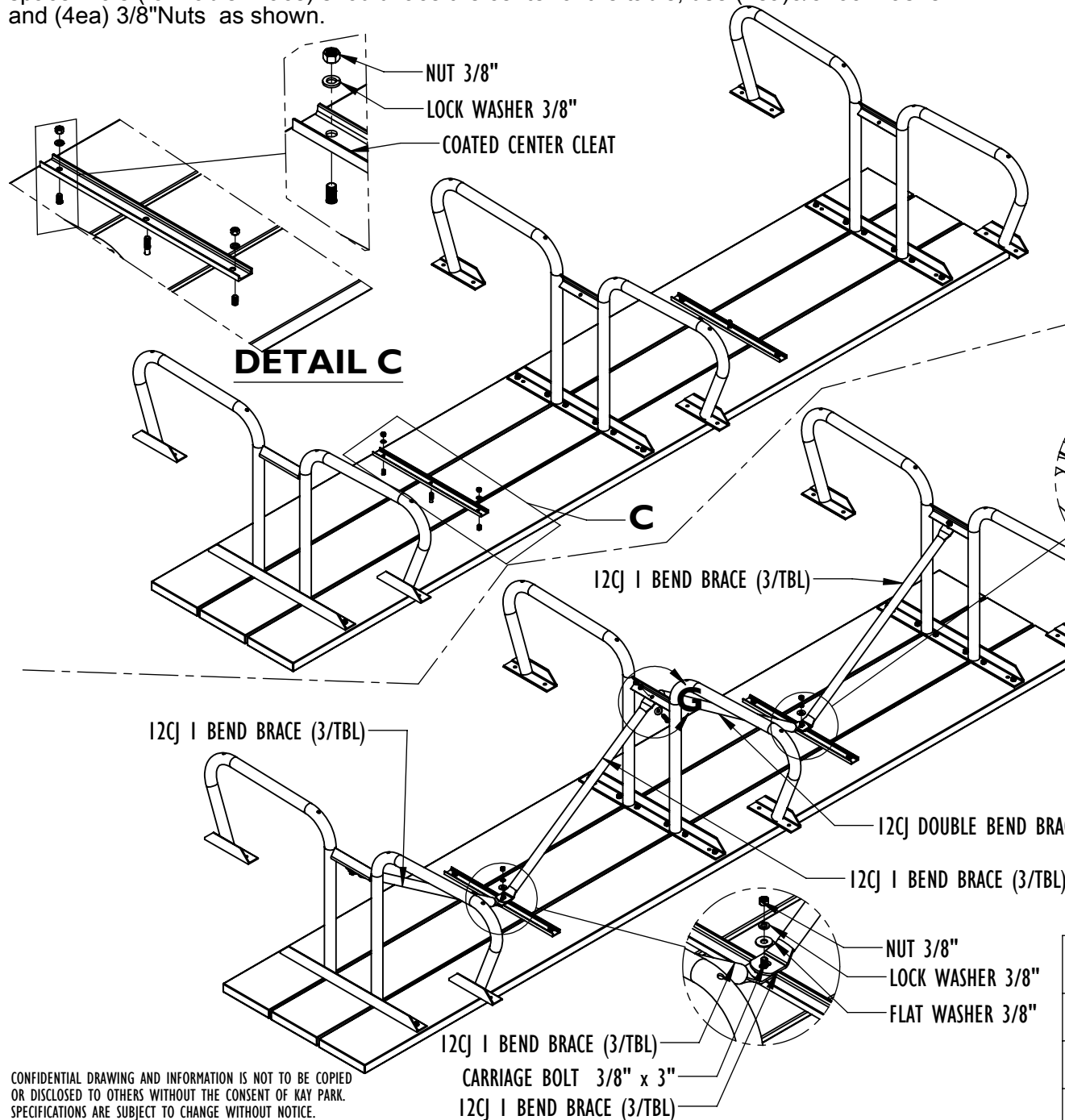

DETAIL G

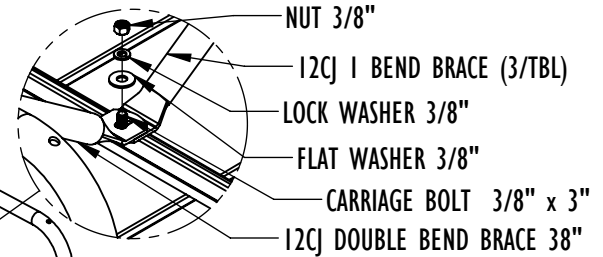

6. Place the braces as shown and use 3ea Hex Bolts 3/8" x 1 1/4", (3ea) Flat washers before brace slot, (3ea) lock washers and (3ea)3/8"nuts as shown. See DETAIL G.

7. Use 2ea flat washers lock washers and nuts on the center Cleat as shown.

CONFIDENTIAL DRAWING AND INFORMATION IS NOT TO BE COPIED OR DISCLOSED TO OTHERS WITHOUT THE CONSENT OF KAY PARK. SPECIFICATIONS ARE SUBJECT TO CHANGE WITHOUT NOTICE.

		Kay Park Rec	
DESC. 1.660D SCH 40 HOT DIPPED GALV. TABLE FRAME W/ 12" 2x10 SYP TREATED PLANK			
MODEL NUMBER. 12CJGW		WT.	
DRAWN BY PAVEL	DATE 2/18/2013	Sheet 1 of 3	SCALE NONE

LEAVE ALL BOLTS LOOSE UNTIL ALL ARE IN PLACE.

8. Flip table at position as shown and place 2ea seat plank use (12ea) Carriage Bolts 3/8" x 2 1/4" , (12ea) 3/8" lock washers and 3/8" Nuts as shown.

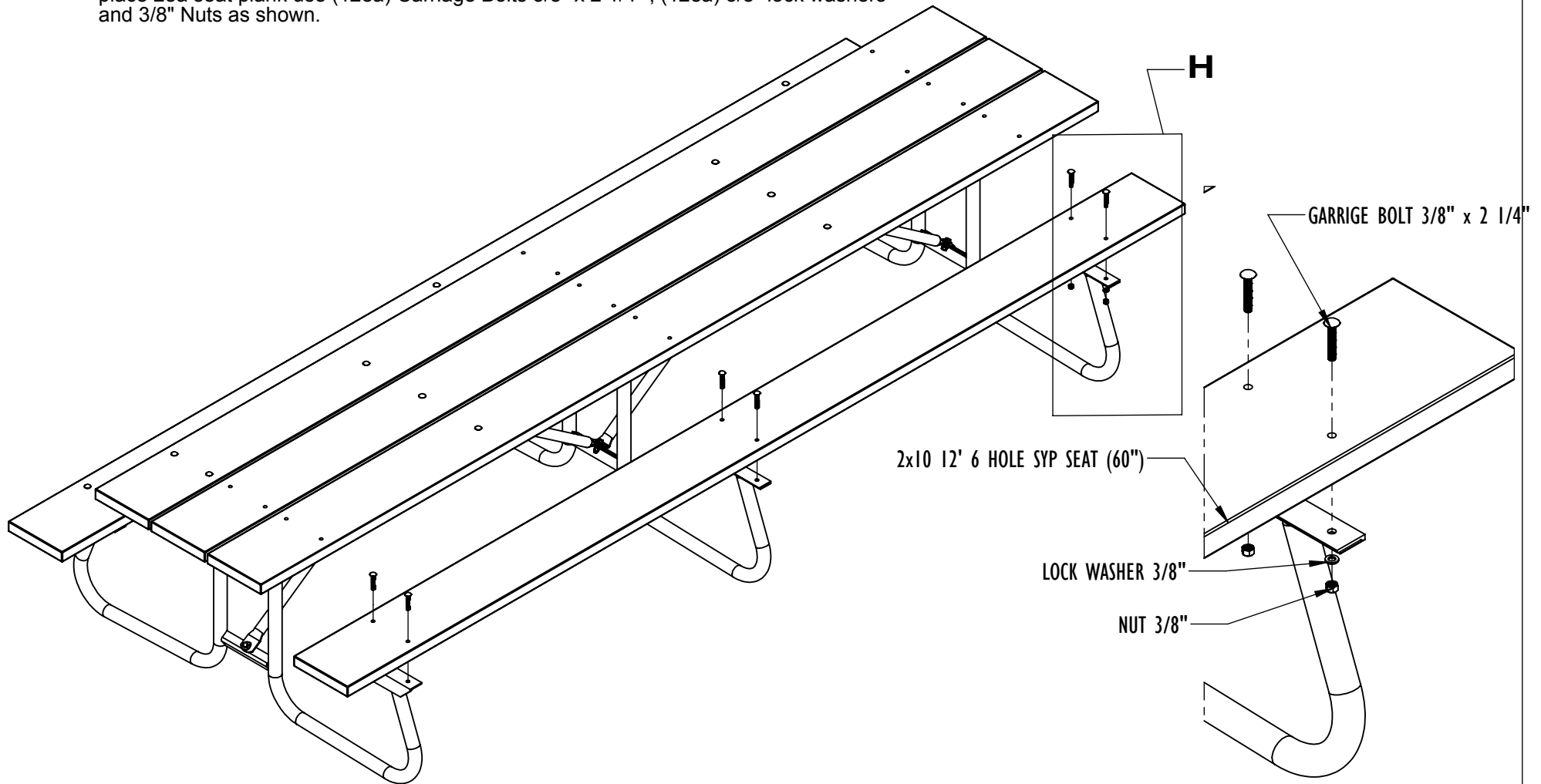

DETAIL H

		<h2 style="margin: 0;">Kay Park Rec</h2>	
DESC. 1.660D SCH 40 HOT DIPPED GALV. TABLE FRAME W/ 12' 2x10 SYP TREATED PLANK			
MODEL NUMBER. 12CJGW			WT.
DRAWN BY PAVEL	DATE 2/18/2013	Sheet 1 of 3	SCALE NONE

CONFIDENTIAL DRAWING AND INFORMATION IS NOT TO BE COPIED OR DISCLOSED TO OTHERS WITHOUT THE CONSENT OF KAY PARK. SPECIFICATIONS ARE SUBJECT TO CHANGE WITHOUT NOTICE.