

2"x 10" Aluminum Foot Plank Mill Finish Material is 6063-T6

2"x 10" Aluminum Seat Plank Anodized Finish Material is 6063-T6

2"x 6" Treated Southern Yellow Pine Mudsills

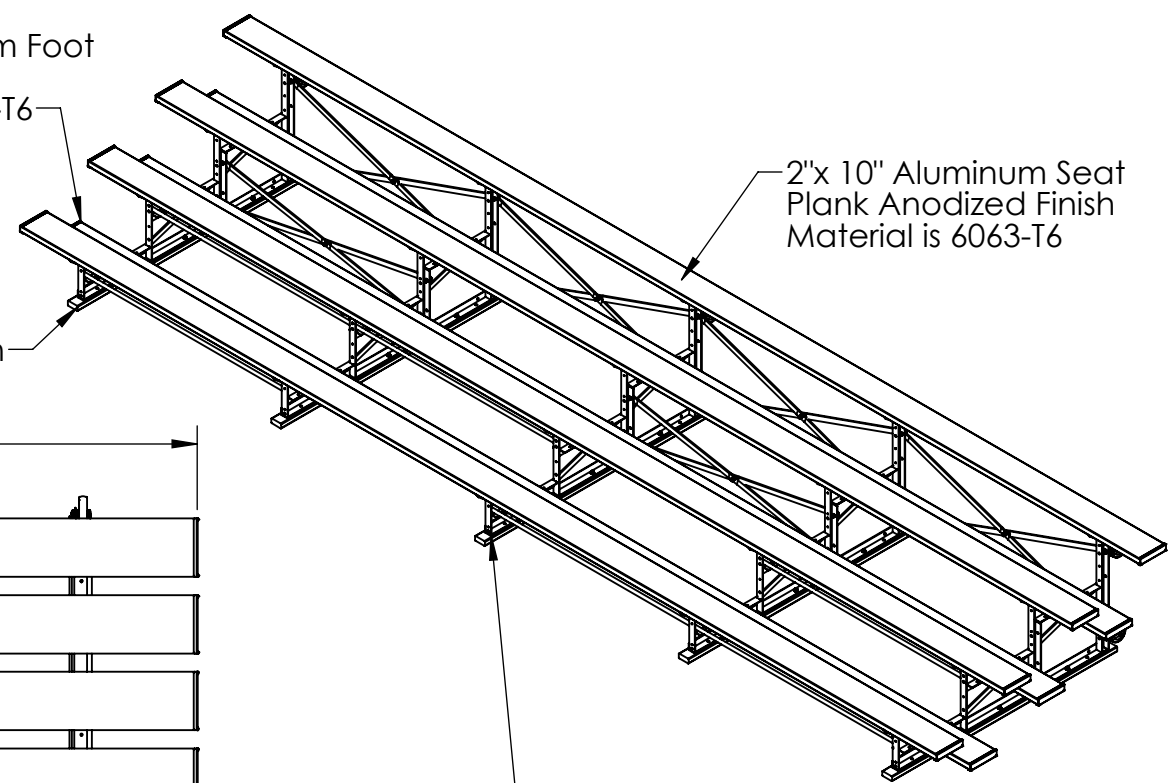

Aluminum Seat Frames Bolted Together Instead of Welding to Reduce Stress Factors Caused By Cracked or Fractured Welds Material is 6061-T6

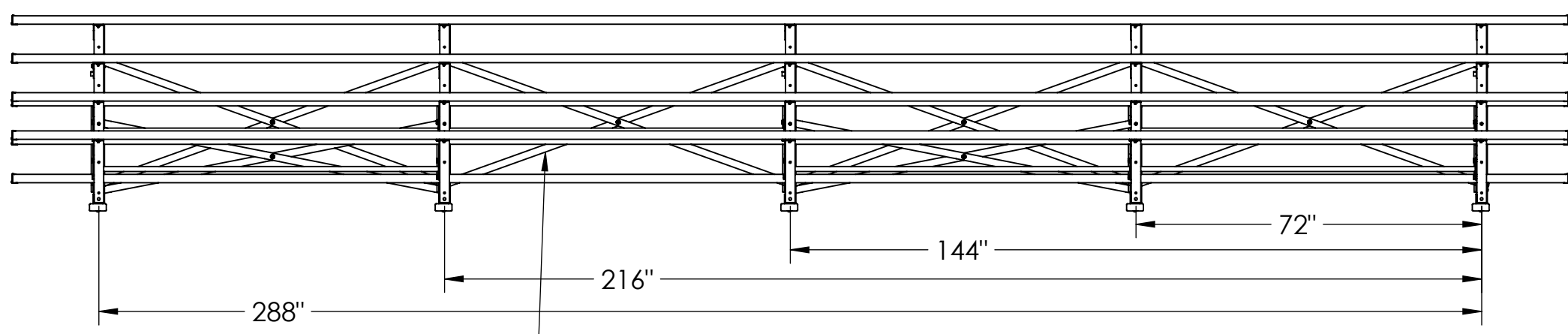

Aluminum X Braces 3/8"x 1 1/2"
Aluminum Flat 6061-T6

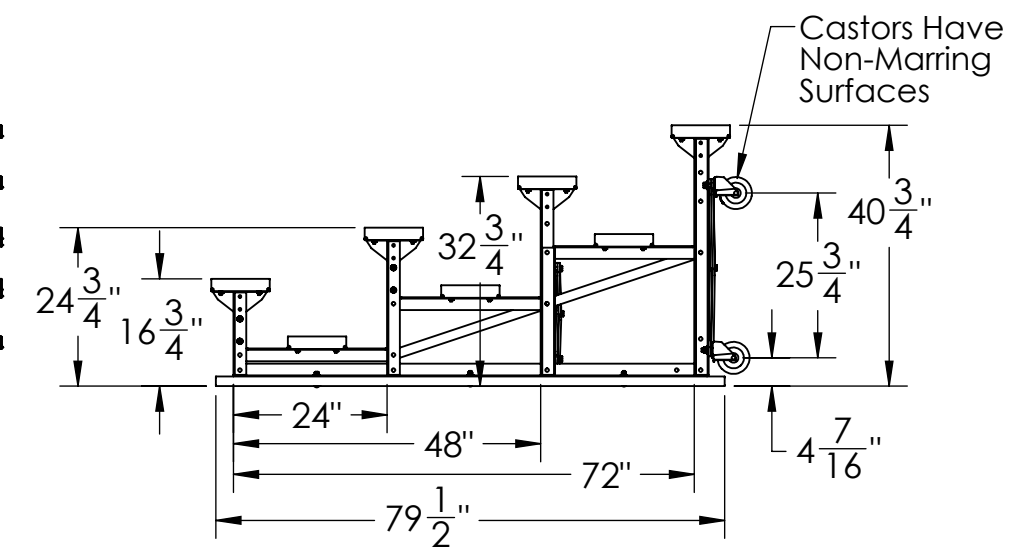

GENERAL NOTES	DIMENSIONS ARE IN INCHES TOLERANCES: LINEAR: ± 1/16" ANGULAR: ± 1°		SHEET SIZE B	SCALE 1:48	REV	 K Industries, Inc. 4 ROW 27' ALUMINUM BLEACHER TIP & ROLL
	CONFIDENTIAL DRAWING. INFORMATION IS NOT TO BE COPIED OR DISCLOSED TO OTHERS WITHOUT CONSENT OF KAY INDUSTRIES. SPECIFICATIONS SUBJECT TO CHANGE WITHOUT NOTICE.		DRAWN BY DAT	11/8/2017	DESC:	
			APPROVED		MATL:	
			LAST SAVED	davet	11/10/2017	
PATH TO PART OR ASSM - S:\CADDRWGS\Solidworks\Bleachers\BLA\BLA Assemblies\Bleachers (17in)\			Configuration - Complete No Rib Plank		11/10/2017 08:06:41	SHEET 1 OF 3